

**From:** [Yousheng Li](#)  
**To:** [Megan Fu](#)  
**Cc:** [Karen Armstrong](#)  
**Subject:** RE: Greenwich Hospital Redevelopment - Detailed Design  
**Date:** Tuesday, 19 March 2024 1:46:02 PM  
**Attachments:** [image001.png](#)  
[image002.png](#)  
[image003.png](#)  
[image004.png](#)  
[image005.png](#)  
[image006.png](#)  
[image007.png](#)  
[image008.png](#)  
[image009.png](#)  
[image010.png](#)  
[image011.png](#)  
[image012.png](#)  
[Greenwich Hospital Redevelopment Waste Management Plan SSDA Issue Updated 190324.pdf](#)

---

Hi Megan,

Please find attached the updated Waste Management Plan which sets out the waste collection hours.

Kind regards,

---

**Yousheng Li**

Senior Urbanist  
Planning



M. [REDACTED]  
W.[ethosurban.com](http://ethosurban.com)



Level 4, 180 George St  
Sydney NSW 2000  
(Gadigal Land)

---

Ethos Urban acknowledges Traditional Owners of Country throughout Australia and recognises the continuing connection to lands, waters, and communities. We pay our respect to Aboriginal and Torres Strait Islander cultures; and to Elders past and present.

We pledge our support to the Uluru Statement from the Heart and embrace the call to walk with the Aboriginal and Torres Strait Islander people in a movement of the Australian people for a better future.

This email is confidential and may contain information that is confidential and privileged. If you are not the intended recipient, please notify us by return email or phone, and delete the original message.

---

**From:** Yousheng Li

**Sent:** Monday, March 18, 2024 2:12 PM

**To:** 'Megan Fu' <[Megan.Fu@planning.nsw.gov.au](mailto:Megan.Fu@planning.nsw.gov.au)>

**Cc:** Karen Armstrong <[REDACTED]>

**Subject:** RE: Greenwich Hospital Redevelopment - Detailed Design

Hi Megan,

Further to the below, the updated Waste Management Plan will be provided tomorrow.

---

**Yousheng Li**

Senior Urbanist  
Planning



M. [REDACTED]  
W.[ethosurban.com](http://ethosurban.com)



Level 4, 180 George St  
Sydney NSW 2000  
(Gadigal Land)

Ethos Urban acknowledges Traditional Owners of Country throughout Australia and recognises the continuing connection to lands, waters, and communities. We pay our respect to Aboriginal and Torres Strait Islander cultures; and to Elders past and present.

We pledge our support to the Uluru Statement from the Heart and embrace the call to walk with the Aboriginal and Torres Strait Islander people in a movement of the Australian people for a better future.

This email is confidential and may contain information that is confidential and privileged. If you are not the intended recipient, please notify us by return email or phone, and delete the original message.

---

**From:** Yousheng Li  
**Sent:** Monday, March 18, 2024 1:12 PM  
**To:** Megan Fu <[Megan.Fu@planning.nsw.gov.au](mailto:Megan.Fu@planning.nsw.gov.au)>  
**Cc:** Karen Armstrong <[REDACTED]>  
**Subject:** RE: Greenwich Hospital Redevelopment - Detailed Design

Hi Megan,

Following our phone discussion last week we have agreed with the approach to amend the Waste Management Plan for collection to occur within the hours of 7am – 7pm, which you have previously advised to be acceptable without needing a quantitative acoustic assessment.

Happy for your response back to the IPC to be drafted on this basis. Will let you know how long the waste consultant needs to update their report, however I imagine it wouldn't take too long.

Kind regards,

---

**Yousheng Li**

Senior Urbanist  
Planning



M. [REDACTED]  
W. [ethosurban.com](http://ethosurban.com)



Level 4, 180 George St  
Sydney NSW 2000  
(Gadigal Land)

Ethos Urban acknowledges Traditional Owners of Country throughout Australia and recognises the continuing connection to lands, waters, and communities. We pay our respect to Aboriginal and Torres Strait Islander cultures; and to Elders past and present.

We pledge our support to the Uluru Statement from the Heart and embrace the call to walk with the Aboriginal and Torres Strait Islander people in a movement of the Australian people for a better future.

This email is confidential and may contain information that is confidential and privileged. If you are not the intended recipient, please notify us by return email or phone, and delete the original message.

---

**From:** Megan Fu <[Megan.Fu@planning.nsw.gov.au](mailto:Megan.Fu@planning.nsw.gov.au)>  
**Sent:** Monday, March 11, 2024 3:41 PM  
**To:** Yousheng Li <[REDACTED]>  
**Cc:** Karen Armstrong <[REDACTED]>  
**Subject:** RE: Greenwich Hospital Redevelopment - Detailed Design

Hi Yousheng

Also, our queries related to impacts from waste collection. Was the doubling of deliveries meant to be doubling of waste collection?

Thanks  
Megan

**Megan Fu**

Principal Planner, Social and Infrastructure Assessments  
Infrastructure Assessments  
**Department of Planning, Housing and Infrastructure**

T 02 9274 6531 E [megan.fu@planning.nsw.gov.au](mailto:megan.fu@planning.nsw.gov.au)

[dphi.nsw.gov.au](http://dphi.nsw.gov.au)

4 Parramatta Square  
12 Darcy Street  
Parramatta NSW 2150



I acknowledge the traditional custodians of the land and pay respects to Elders past and present. I also acknowledge all Aboriginal and Torres Strait Islander staff working with the NSW Government.

Please consider the environment before printing this email.

---

**From:** Megan Fu

**Sent:** Monday, 11 March 2024 3:24 PM

**To:** Yousheng Li <[REDACTED]>

**Cc:** Karen Armstrong <[REDACTED]>

**Subject:** RE: Greenwich Hospital Redevelopment - Detailed Design

Hi Yousheng

There appears to be no quantitative assessment from the Acoustic consultant regarding the doubling of deliveries. This needs to be clarified and updated.

Thanks  
Megan

**Megan Fu**

Principal Planner, Social and Infrastructure Assessments  
Infrastructure Assessments  
**Department of Planning, Housing and Infrastructure**

T 02 9274 6531 E [megan.fu@planning.nsw.gov.au](mailto:megan.fu@planning.nsw.gov.au)

[dphi.nsw.gov.au](http://dphi.nsw.gov.au)

4 Parramatta Square  
12 Darcy Street

Parramatta NSW 2150



I acknowledge the traditional custodians of the land and pay respects to Elders past and present. I also acknowledge all Aboriginal and Torres Strait Islander staff working with the NSW Government.

Please consider the environment before printing this email.

---

**From:** Yousheng Li <[REDACTED]>  
**Sent:** Friday, 8 March 2024 4:47 PM  
**To:** Megan Fu <[Megan.Fu@planning.nsw.gov.au](mailto:Megan.Fu@planning.nsw.gov.au)>  
**Cc:** Karen Armstrong <[REDACTED]>; David Gibson <[David.Gibson@planning.nsw.gov.au](mailto:David.Gibson@planning.nsw.gov.au)>; Karen Harragon <[Karen.Harragon@planning.nsw.gov.au](mailto:Karen.Harragon@planning.nsw.gov.au)>  
**Subject:** RE: Greenwich Hospital Redevelopment - Detailed Design  
**Importance:** High

Hi Megan,

Further to the below, with regards to waste the Waste Management Plan has been updated (attached) to identify waste collection hours. The existing arrangement is for 24/7 collection (with most vehicle movements still occurring within business hours). This is to be maintained under the proposed redevelopment as it is needed to meet requirements of an operational hospital.

This is supported by a letter from Acoustic Logic, confirming the proposed waste arrangements will not have adverse noise impacts including for the following reasons:

- There is no change in the proposed hours of waste collection.
- Access/roadways to loading dock is unchanged. Also noting that the external distance of travel required for waste collection vehicles is significantly reduced with the proposed scheme.
- The future loading dock will be enclosed reducing and minimising noise to residents from the emptying of bins, which are typically the loudest associated activities.

Kind regards,

---

**Yousheng Li**

Senior Urbanist  
Planning

M. [REDACTED]  
W. [ethosurban.com](http://ethosurban.com)



Level 4, 180 George St  
Sydney NSW 2000  
(Gadigal Land)

---

Ethos Urban acknowledges Traditional Owners of Country throughout Australia and recognises the continuing connection to lands, waters, and communities. We pay our respect to Aboriginal and Torres Strait Islander cultures; and to Elders past and present.

We pledge our support to the Uluru Statement from the Heart and embrace the call to walk with the Aboriginal and Torres Strait Islander people in a movement of the Australian people for a better future.

This email is confidential and may contain information that is confidential and privileged. If you are not the intended recipient, please notify us by return email or phone, and delete the original message.

---

**From:** Yousheng Li  
**Sent:** Friday, March 8, 2024 4:39 PM  
**To:** 'Megan Fu' <[Megan.Fu@planning.nsw.gov.au](mailto:Megan.Fu@planning.nsw.gov.au)>  
**Cc:** Karen Armstrong <[REDACTED]>; [david.gibson@planning.nsw.gov.au](mailto:david.gibson@planning.nsw.gov.au); Karen Harragon <[Karen.Harragon@planning.nsw.gov.au](mailto:Karen.Harragon@planning.nsw.gov.au)>  
**Subject:** RE: Greenwich Hospital Redevelopment - Detailed Design

Hi Megan,

Please find attached response from Travers Bushfire with regards to your queries around the Bushfire Protection Assessment.

I will be sending a separate email responding to the waste matter shortly.

Kind regards,

---

**Yousheng Li**

Senior Urbanist  
Planning



M. [REDACTED]  
W. [ethosurban.com](http://ethosurban.com)



Level 4, 180 George St  
Sydney NSW 2000  
(Gadigal Land)

---

Ethos Urban acknowledges Traditional Owners of Country throughout Australia and recognises the continuing connection to lands, waters, and communities. We pay our respect to Aboriginal and Torres Strait Islander cultures; and to Elders past and present.

We pledge our support to the Uluru Statement from the Heart and embrace the call to walk with the Aboriginal and Torres Strait Islander people in a movement of the Australian people for a better future.

This email is confidential and may contain information that is confidential and privileged. If you are not the intended recipient, please notify us by return email or phone, and delete the original message.

---

**From:** Megan Fu <[Megan.Fu@planning.nsw.gov.au](mailto:Megan.Fu@planning.nsw.gov.au)>  
**Sent:** Wednesday, February 21, 2024 12:26 PM  
**To:** Yousheng Li <[REDACTED]>  
**Cc:** Karen Armstrong <[REDACTED]>; [david.gibson@planning.nsw.gov.au](mailto:david.gibson@planning.nsw.gov.au); Karen Harragon <[Karen.Harragon@planning.nsw.gov.au](mailto:Karen.Harragon@planning.nsw.gov.au)>  
**Subject:** Greenwich Hospital Redevelopment - Detailed Design

Hi Yousheng

The Commission has requested a response to proposed changes to the Department's recommended conditions and queries regarding the recommended conditions. We require further information in relation to bushfire assessment, landscaping and waste management to be able to complete our response to the Commission.

We note that the Bushfire Protection Assessment (BPA) identified in Section 3.3 that "It is recommended that the entire site, with the exception of the currently vegetated area to the south west of the site (OPA) be managed as an Inner Protection Area (IPA). However, the recommendations of the

BPA does not include this but recommends that “APZs are to be provided to the proposed development as outlined in Table 2-2 and as generally depicted within SCHEDULE 1.” We note that the APZ outlined in Table 2-2 and depicted within Schedule 1 is a 23 metre portion of the site that adjoins the bushland to the south-west. Please clarify whether the intention is to manage the APZ only or the remainder of the site as an IPA and the bushland as an OPA? We note that IPAs are limited to 15 per cent canopy cover and the proposed development would exceed that as would the bushland in relation to OPA. Please identify if any landscape changes are required to manage bush fire risk or further clarification from a bushfire consultant confirming that the landscaping meets asset protection zone requirements?

Also, the current landscape plans seeking approval have been modified since the bushfire assessment was undertaken. Please provide confirmation from the bushfire consultant that the latest plans meet the requirements for IPAs, including canopy cover? Also, please provide heights of trees for bushland regeneration planting?

The waste management plan does not identify waste collection hours and/or address noise impacts associated with increased operational waste collection. Please provide details of loading dock operations in relation to waste collection and if any potential mitigation measures are required to address impacts from waste collection activities?

Please provide a response by Monday, 26 February 2024 or please notify us when a response will be provided if that timeline is an issue.

Feel free to contact me on 9274 6531 if you wish to discuss.

Thanks  
Megan

**Megan Fu**

Principal Planner, Social and Infrastructure Assessments  
Infrastructure Assessments  
**Department of Planning, Housing and Infrastructure**

T 02 9274 6531 E [megan.fu@planning.nsw.gov.au](mailto:megan.fu@planning.nsw.gov.au)

[dphi.nsw.gov.au](http://dphi.nsw.gov.au)

4 Parramatta Square  
12 Darcy Street  
Parramatta NSW 2150



I acknowledge the traditional custodians of the land and pay respects to Elders past and present. I also acknowledge all Aboriginal and Torres Strait Islander staff working with the NSW Government.

Please consider the environment before printing this email.



Waste Audit & Consultancy Services (Aust) Pty Ltd  
Level 21, 133 Castlereagh Street  
Sydney, NSW 2000  
02 9199 4521  
[www.wasteaudit.com.au](http://www.wasteaudit.com.au)

## Greenwich Hospital Redevelopment

### Combined Operational, Demolition, and Construction Waste Management Plan

State Significant Development,  
Application Number SSD-11619238

Prepared for TSA Management

March 19, 2024

# Table of Contents

1	Introduction.....	3
2	Applicable Legislation, Standards and Guidelines.....	4
3	Reference Documents and Reports .....	4
4	Scope of Demolition and Construction Works .....	5
5	Risk Management and Reporting .....	5
6	Demolition and Construction Waste Objectives and Targets.....	6
7	Demolition and Construction Waste Management Strategies .....	6
8	Demolition and Construction Waste Management Principles.....	7
	8.1 General Principles .....	7
	8.2 Liquid Waste Management.....	7
	8.3 Asbestos Containing Materials .....	7
9	Demolition Waste .....	8
10	Construction Waste .....	10
11	Operational Waste .....	11
	11.1 Expected Materials Streams.....	11
	11.2 Predicted Operational Volumes .....	11
12	Operational Waste Management Processes.....	13
	12.1 Clinical Wastes.....	13
	12.2 General Waste .....	15
	12.3 Cardboard and Paper Recycling .....	15
	12.4 Secure Document Destruction .....	15
	12.5 Commingled Recycling .....	15
	12.6 Food Waste Recycling .....	15
	12.7 Polystyrene Recycling .....	16
	12.8 Specialised Recycling (E-Waste, Printer Cartridges, Lamps, Batteries) .....	16
13	Operational Waste Stream Management.....	16
	13.1 Labelling and Tracking .....	16
	13.2 Mobile Garbage Bins (MGBs) and Trolleys.....	16
	13.3 Handling of Bags/Bin Liners .....	17
	13.4 Spill Management .....	17
	13.5 Auditing.....	18
14	Waste and Recycling Contractor Requirements .....	18
	14.1 Transport and Disposal .....	18
	14.2 Servicing, Access, and Reporting.....	18
15	Storage and Loading Areas.....	19
16	Internal Bins .....	19
	16.1 Administrative Areas.....	19
	16.2 Clinical Areas .....	20
17	Staff & Contractor Education.....	20
18	Operational Resource Recovery Targets .....	20
19	Ongoing Performance Reporting.....	20
	Appendix 1: Glossary .....	21
	Appendix 2: Clinical Waste Stream Management.....	23
	Appendix 3: Signage Examples - Hazardous Waste .....	26
	Appendix 4: Signage Examples - Internal and Loading Dock .....	27
	Appendix 5: Site Demolition Plans .....	29
	Appendix 6: Site Construction Plans.....	30
	Appendix 7: Materials Movement, Storage, and Collection .....	33
	Appendix 8: Lane Cove Council Waste Management Controls .....	38
	Appendix 9: Waste Management Bins and Equipment .....	47



# 1 Introduction

This combined Operational, Demolition, and Construction Waste Management Plan is submitted to the Department of Planning, Industry and Environment (DPIE) in support of a State Significant Development Application (SSD-13619238) for the redevelopment of Greenwich Hospital into an integrated hospital and seniors living facility on land identified as 97-115 River Road, Greenwich (the site). The extent of the site is shown below.

**Figure 1: Location Plan**



The subject proposal is for the detailed design and construction of the facility following its concept approval under SSD-8699. Specifically, SSD-13619238 seeks approval for the following:

- Construction of a new hospital facility and integrated healthcare campus comprising of hospital, residential aged care, seniors housing, overnight respite, across:
  - A new main hospital building up to RL 80.0;
  - Two new seniors living buildings, Northern building up to RL 56.36, and Southern building up to RL 60.65;
  - A new 2-3 respite care building up to RL 56.9;
- Construction of associated site facilities and services, including pedestrian and vehicular access and basement parking;
- Site landscaping and infrastructure works; and
- Preservation of Pallister House which will continue to host dementia care and administrative functions.

This report provides details of:

- Calculations of predicted waste types, quantities, and management processes for the following project stages:
  - Demolition of existing structures
  - Construction of new facilities
  - Ongoing facility operations
- Materials movement pathways and storage area design and layout
- Staff engagement strategies and education programs
- Private waste contractor requirements
- Lane Cove Council planning requirements regarding waste management

A Development Consent for the project was issued on 10 November 2020 for SSD-8699 (concept proposal for the redevelopment of Greenwich Hospital).

In accordance with Section 4.39 of the Environmental Planning & Assessment Act 1979 (EP&A Act), the Secretary's Environmental Assessment Requirements (SEARs) for the Detailed Design component of the redevelopment (SSD-13619238) were issued on 24 February 2021.

Consequently this report has been prepared to respond to the following SEARs:

**Table 1: SEARs Requirements**

Stage/Item	Description of Requirement	Report Section
<b>EIS Item 18. Waste</b>	<ul style="list-style-type: none"> <li>Identify, quantify and classify the likely waste streams to be generated during construction and operation.</li> <li>Provide the measures to be implemented to manage, reuse, recycle and safely dispose of this waste.</li> <li>Identify appropriate servicing arrangements (including but not limited to, waste management, loading zones, mechanical plant) for the site.</li> <li>Provide a hazardous materials survey of existing aboveground buildings that are proposed to be demolished or altered</li> </ul>	<p>Sections 9-12</p> <p>Section 13</p> <p>Sections 13-18</p> <p>See separate 2018 GreenCap report</p>
<b>Concept Proposal B29. Waste</b>	<ul style="list-style-type: none"> <li>All future applications for new built form must include Waste Management Plans to address storage, collection, vermin control, hygiene and management of waste and recycling within the development and during construction and demolition works.</li> </ul>	Sections 13-18

## 2 Applicable Legislation, Standards and Guidelines

The following have been referred to in compiling this report:

- NSW Protection of the Environment Operations Act 1997
- NSW Protection of the Environment Operations (Waste) Regulation 2014, Part 11
- NSW Protection of the Environment (General) Operations Act 1998
- NSW Waste Avoidance and Resource Recovery Act 2001
- NSW EPA Waste Classification Guidelines 2014
- Lane Cove Council Development Control Plan Part Q - Waste Management & Minimisation

## 3 Reference Documents and Reports

The following diagrams, documents and reports have been consulted in compiling this report:

- DD-SW-0100\_EXISTING SITE PLAN\_P8
- DD-SW-0101\_PROPOSED SITE PLAN\_P9
- DD-SW-0121\_STAGE 1.1 PLAN-DEMOLITION\_P7
- DD-SW-0124\_STAGE 3.1 PLAN-DEMOLITION\_P7
- DD-SW-0122\_STAGE 1.2 PLAN - CONSTRUCTION\_P7
- DD-SW-0123\_STAGE 2 PLAN - CONSTRUCTION\_P7
- DD-SW-0125\_STAGE 3.2 PLAN - CONSTRUCTION\_P7
- DD-SW-0126\_STAGE 4 PLAN - CONSTRUCTION\_P7
- DD-SW-0127\_STAGE 5 PLAN - CONSTRUCTION\_P7

- Attachment\_1605-220217-Loading Dock Option
- Attachment\_1605-220218-Staging Option-Preferred
- WF-0410-0416\_WORKFLOW DIAGRAMS COMBINED- WASTE MANAGEMENT - HEALTH & CARE
- WF-0420\_WORKFLOWS - SL - WASTE MANAGEMENT - L1\_P2
- WF-0421\_WORKFLOWS - SL - WASTE MANAGEMENT - L2\_P2
- GreenCap *Hazardous Material Risk Assessment* April 2018
- Douglas Partners *Report on Preliminary Site Investigation (Contamination)* August 2018

## 4 Scope of Demolition and Construction Works

The demolition and construction components of the project will take place across several stages and sub-stages as summarised below and illustrated in the drawings in Appendix 7.

**Table 2: Scope of Demolition & Construction Works**

Stage	Proposed Work Relevant to this Report
1.1	Demolition of existing buildings (Bluegum, pool, reception, and adjacent structures) Demolition of existing roadways Removal of non-significant vegetation
1.2	Construction of new Hospital building including Podium, Tower and basement carpark Construction of new roadways and external carparks
2	Construction of new Hospital building including Garden Terraces
3.1	Demolition of existing buildings (Hospital, Riverglen, and adjacent structures) Demolition of existing roadways and carparks Removal of non-significant vegetation
3.2	Construction of Seniors Living South and surrounding areas and landscaping
4	Construction of Seniors Living North and surrounding areas and landscaping
5	Construction of Respite

## 5 Risk Management and Reporting

Legislation specifies that the generator of waste is the owner of the material until it crosses a weighbridge into a licensed processing or disposal facility. Waste contractors and construction contractors will be the primary transporters of waste off-site; accordingly, contractors will be required to provide monthly reports to the Project Managers on waste reused, re-processed/ recycled, and sent to landfill.

All reports will include the following information:

- Date and time material removed
- Material type
- Amount of material (in kg and/or cubic metres)
- Processing facility material taken to
- Processing facility licensing information
- Vehicle registration and waste contractor's company details

This information will be kept on site in a data file (printed and/or electronic) and made available for inspection to authorised council officers at any time during site works. On conclusion of works, the construction contractor will retain all documentation and make it available for inspection.

## 6 Demolition and Construction Waste Objectives and Targets

This Waste Management Plan will be implemented throughout the project’s demolition and construction phases. The project’s waste management objectives will include:

- Meeting all waste management standards while ensuring the health and safety of the workers on the project
- Maximising the quantities of materials diverted from landfill by reusing, recycling and reprocessing off-site
- Disposal of no more than 20% of residual waste materials to a licensed landfill in accordance with both regulatory and legal requirements
- The diversion from landfill of 80% of construction waste by weight, to meet the criteria of the NSW State Government’s waste legislation, policy settings and regulatory regime

Management strategies and responsibilities for ensuring these objectives are achieved are detailed in Section 7.

## 7 Demolition and Construction Waste Management Strategies

The following waste management strategies for the project will operate over the design, procurement, demolition, and construction (including fitout) stages of the project:

**Table 3: Management Strategies**

Management Strategies	Responsibilities
<b>Design:</b> Use of modular components in design Use of prefabricated components in design Design for materials to standard sizes Design for operational waste minimisation	Architect & Engineer Architect, Builder, Subcontractors Architect, Subcontractors Architect & Builder
<b>Procurement:</b> Select recycled and reprocessed materials Select components that are reusable after deconstruction	Architect, Engineer, Builder, Subcontractors Architect, Engineer & Builder
<b>Pre-Demolition:</b> Waste management plan to be reviewed and amended as required to address any changes in project scope Hazardous materials survey to be undertaken prior to commencements of any demolition works	Project Manager, Builder
<b>Construction:</b> Use the waste hierarchy principles of avoidance, reuse, reduction, and recycling Minimisation of recurring packaging materials Returning packaging to the supplier Separation and recycling of materials off site Monitor and audit correct usage of bins Monitor and audit waste contractor(s)	Builder & Waste Contractor  Subcontractors Builder & Subcontractors Waste Contractor Builder & Waste Contractor Builder

## 8 Demolition and Construction Waste Management Principles

### 8.1 General Principles

The following standard waste management hierarchy principles have been used to guide this waste management plan:

**Avoid:** Use practices that avoid the creation of waste products in the first place (e.g., the Design for Manufacture and Assembly (DfMA) process that combines the manufacture of building components, such as wall systems and facades, in an efficient factory environment, with on-site construction assembly. For details of this process please go to:

<https://architectus.com.au/insight/design-for-manufacture-and-assembly-dfma/>

**Reduce:** Reduce the use of materials during demolition that require treatment or disposal

**Reuse:** Ensure that wherever possible, materials are reused either on site or offsite:

- Identify and put systems in place to separate and store materials for onsite reuse
- Identify the potential applications for reuse offsite and facilitate this process

**Recycle/Recover:** Identify all recyclable waste products to be produced on site:

- Provide systems, bins, and signage for separating and stockpiling of recyclables
- Process the material for recycling either onsite or offsite

**Treat/Dispose:** Waste products which cannot be reused or recycled will be removed and treated/disposed of at appropriately licensed facilities. To minimise vehicle movements and transportation costs, bins should be monitored for fullness and collected on an efficient schedule.

### 8.2 Liquid Waste Management

- Ensure water is used in moderation and no taps are left continuously running
- Use any grey water produced on site for irrigation or for dust suppression
- Only discharge clean water into storm water
- Manage all wastewater and runoff in accordance with Sydney Water requirements

### 8.3 Asbestos Containing Materials

In regard to disposal of asbestos-containing materials, there are regulatory requirements under Clause 42 of the *Protection of the Environment Operations (Waste) Regulation 2005* that apply to the management of asbestos waste. Should any materials be suspected of being (or containing), asbestos, the following process will be followed:

- Treat the material as asbestos unless proven otherwise
- Do not disturb the material (i.e., shift or place into a container)
- Send the materials to a suitably qualified laboratory for testing
- If determined not to be asbestos, then the materials can be managed as an inert waste
- If determined to be asbestos then the materials must be managed by a licenced contractor for packaging, removal and disposal
- If the material has accidentally been uncovered, then the area should be cleared, barriers erected to prevent access, NSW WorkCover and EPA notified, and if the material is broken, it should be covered with a fine spray/mist of water.

Only workers trained in asbestos removal techniques will be allowed to manage the removal of asbestos-contaminated soil and any material contained in existing structures.

## 9 Demolition Waste

Table 4 shows estimated quantities of demolition waste to be generated, and management strategies for each type of material, based on our understanding of structures to be demolished and excavation works to be undertaken. Specific disposal/recycling facilities are not shown, as waste removal contractors have not yet been appointed for the project.

**Table 4: Demolition Waste - Expected Materials Streams**

Materials on Site		Destination/Treatment		
Type of Material	Estimated m <sup>3</sup>	Onsite (Reuse/Recycle)	Offsite (Reuse/Recycle)	Disposal (Landfill)
Excavated Soil, Rock	13,600	Possible onsite reuse in landscaping works	Material to be taken to facility for processing for reuse at other sites	No disposal to landfill
Bricks	1,000	Separated on site and crushed for use in pavement and/or temporary access road construction	Acceptable quality bricks collected by contractor for reuse. Unusable bricks collected and recycled at recycling facility to be used in aggregate gravel products	No disposal to landfill
Trees & Vegetation	200	Possible onsite reuse	Material to be taken to organic waste facility for processing for reuse in landscaping works	No disposal to landfill
Roof Tiles	100	No on-site reuse or recycling	Sent for reuse if feasible and/or recycling depending on condition	No disposal to landfill
Bitumen	100	No on-site reuse	Collected by contractor for recycling at dedicated facility	No disposal to landfill
Concrete	60	Separated on site and crushed for use in pavement and/or temporary access road construction	Acceptable quality bricks collected by contractor for reuse. Unusable bricks collected and recycled at recycling facility to be used in aggregate gravel products	No disposal to landfill
Metals	60	No on-site reuse	Collected by contractor for separation into different metal types for recycling	No disposal to landfill
General Waste (All Materials Unsuitable for Reuse/Recycling)	60	No on-site reuse or recycling	Collected by the waste contractor for disposal at landfill	Disposal to landfill
Floor Coverings	60	No on-site reuse	Collected in designated bin and sent for recycling if of sufficient quality; otherwise sent to landfill	Material that cannot be recycled will be sent to landfill
Structural & Fencing Timber	50	Possible onsite reuse	Untreated recyclable timber will be collected and recycled at timber yard. Unrecyclable timber will be sent to landfill	Material that cannot be recycled will be sent to landfill
Glass	40	No on-site reuse or recycling	Sent for reuse if feasible and/or recycling depending on condition	No disposal to landfill

Materials on Site		Destination/Treatment		
Type of Material	Estimated m <sup>3</sup>	Onsite (Reuse/Recycle)	Offsite (Reuse/Recycle)	Disposal (Landfill)
Hazardous Materials	30	No on-site reuse or recycling	Collected by specialist contractor for treatment and disposal	Disposal to licensed landfill
Ceiling Tiles	20	No on-site reuse or recycling	Collected by specialist contractor for recycling	No disposal to landfill
Lighting Fixtures, Lamps (Non-Hazardous)	30	No on-site reuse or recycling	Collected by specialist contractor for recycling	No disposal to landfill
Wiring, Electrical Fittings	30	No on-site reuse	Collected by specialist metal subcontractor for separation into different metal types for recycling	No disposal to landfill
Plumbing, Fixtures	30	No on-site reuse		No disposal to landfill
Plasterboard	20	No on-site reuse	Material to be separated onsite and collected by contractor for recycling for use as soil improver with gypsum removed by recycler	Material that cannot be recycled will be sent to landfill
Bathroom & Kitchen Tiles	10	No on-site reuse or recycling	Sent for reuse if feasible and/or recycling depending on condition	No disposal to landfill
<b>TOTAL MATERIALS</b>	<b>15,540</b>	The development's demolition phase will produce around <b>15,540 m<sup>3</sup></b> of waste materials, of which <b>15,540 m<sup>3</sup></b> or <b>99%</b> can potentially be diverted from landfill, by being reused on site, or recycled off-site at a dedicated facility.		

## 10 Construction Waste

Table 5 shows expected volumes resulting from the construction process, including materials generated from deliveries, such as pallets, pallet wrap, cardboard packaging, and general waste and recyclables disposed of by contractor staff, based on the works to be undertaken. Specific disposal/recycling facilities are not shown, as waste removal contractors have not yet been appointed for the project.

**Table 5: Construction Waste - Expected Materials Streams**

Materials on Site		Destination		
Type of Material	Estimated m <sup>3</sup>	Onsite (Reuse/Recycle)	Offsite (Reuse/Recycle)	Disposal (Landfill)
Soft Plastics (e.g. pallet wrapping)	85	Possible onsite reuse	Collected by contractor and taken to recycling facility	No disposal to landfill
Used Pallets	83	Reuse on site for materials storage	Collected by contractor and taken to recycling facility	No disposal to landfill
Paper/Cardboard Recycling	66	Reuse cardboard boxes for storage where possible	Separated onsite into dedicated receptacles and collected by the waste contractor for recycling	No disposal to landfill
Metal Offcuts, Wiring, etc.	58	No on-site reuse	Collected by contractor for separation into different metal types for recycling	No disposal to landfill
General Waste	55	No on-site reuse or recycling	Separated onsite into dedicated receptacles and collected by waste contractor for disposal	Disposal to landfill
Plasterboard Offcuts	52	No on-site reuse	Material to be separated onsite and collected by contractor for recycling for use as soil improver with gypsum removed by recycler	Material that cannot be recycled will be sent to landfill
Floor Coverings	50	No on-site reuse	Collected in designated bin and sent for recycling if of required quality; otherwise sent to landfill	Material that cannot be recycled will be sent to landfill
Recyclable Glass, Metal, & Plastic Containers	41	No on-site reuse	Separated onsite into dedicated receptacles and collected by the waste contractor for recycling	No disposal to landfill
Timber Offcuts	39	Reuse for formwork where possible	Untreated recyclable timber will be collected and recycled at timber yard. Unrecyclable timber will be sent to landfill	Material that cannot be recycled will be sent to landfill
Concrete (Excess)	33	Separated on site and crushed for use in access road construction	Collected by contractor and taken to concrete recycling facility	No disposal to landfill
Glass (Excess)	28	No on-site reuse or recycling	Sent for reuse if feasible and/or recycling depending on condition	No disposal to landfill
<b>TOTAL MATERIALS</b>	<b>589 m<sup>3</sup></b>	The development's construction phase will produce around <b>589 m<sup>3</sup></b> of waste materials, of which <b>534 m<sup>3</sup></b> or <b>90.2%</b> can potentially be diverted from landfill, by being reused on site, or recycled off-site at a dedicated facility.		



## 11 Operational Waste

### 11.1 Expected Materials Streams

The following materials streams will be generated from the development's ongoing operations:

**Table 6: Materials Streams**

Material Stream	Health & Care	Seniors Living
General Waste	✓	✓
Cardboard & Paper Recycling	✓	✓
Confidential Paper Recycling	✓	✓
Commingled Recycling	✓	✓
Food Organics Recycling	✓	✓
Cooking Oil Recycling	✓	
Polystyrene Recycling	✓	
Clinical Waste	✓	✓
Pharmaceutical Waste	✓	✓
Cytotoxic Waste	✓	
Sanitary Waste	✓	✓
Sharps Waste	✓	
E-Waste Recycling	✓	✓
Lamp Recycling	✓	✓
Bulky Used Items	✓	✓

Garden waste will also be generated, but it is expected that this will be removed by the development's garden maintenance contractor and so it has not been included in calculations.

### 11.2 Predicted Operational Volumes

To calculate these, we have used the existing Hospital's waste data for January-June 2021 as a guide, and multiplied volumes of general waste by a factor of 6.25, and a factor of 6.50 for the site's other streams, taking into account reduced occupancy in 2021 due to COVID-19 and an increase in the number of Hospital beds from 74 to 130, and 89 Seniors Living apartments.

For food organics recycling, for which the current hospital does not have a recycling program, we have estimated expected quantities based on the percentage of this material likely to be recoverable from the general waste.

Tables 7 and 8 show expected daily volumes in litres, bin and equipment sizes and requirements, and recommended collection frequencies for the main materials streams listed above, based on full occupancy of the Hospital and Seniors Living.

Collections of other streams (E-Waste, Lamps, and Bulky Items) will be done on an ad-hoc basis as required; figures in Table 7 for these streams are for both buildings.

As cooking will take place on site, used oil recycling facilities will also be provided in the central bin storage room. The estimated daily volume of this waste is around 20 litres.

The site's private waste contractor, Suez, will collect all materials from the central storage room as shown in the drawings in Appendix 7.

**Table 7: Equipment & Collection Frequencies - Hospital**

Material Stream	Daily Litres	Bin Size (Litres)	No.	Collection Frequency	m <sup>2</sup> Per Bin	Total Area m <sup>2</sup>
General Waste	10,799	1100	11	7 per week	1.33	14.63
Cardboard & Paper Recycling	2,505	1100	4	3 per week	1.33	5.32
Confidential Paper Recycling	86	240	2	1 per week	0.43	0.85
Commingled Recycling	492	240	8	3 per week	0.43	3.41
Food Organics Recycling	474	120	5	7 per week	0.26	1.30
Cooking Oil Recycling	20	500	1	1 per month	0.50	0.50
Polystyrene Recycling	500	1100	1	3 per week	1.33	1.33
Clinical Waste	123	240	6	1 per month	0.43	2.56
Pharmaceutical Waste	8	120	1	1 per quarter	0.26	0.26
Cytotoxic Waste	17	120	2	1 per month	0.26	0.52
Sanitary Waste	574	28	10	1 per week	0.10	1.00
Sharps Waste	<5	5	To be determined			
E-Waste Recycling	Irregular	240	1		0.43	0.43
Lamp Recycling	Irregular	240	1		0.43	0.43
Bin Wash Area	N/A					4
Bulky Goods Area	N/A					8
Circulation Space (+30% of bin footprint)	N/A					10.56
<b>Total</b>	<b>15,596</b>					<b>55.09</b>

**Table 8: Equipment & Collection Frequencies – Seniors Living**

Material Stream	Daily Litres	Bin Size (Litres)	No.	Collection Frequency	m <sup>2</sup> Per Bin	Total Area m <sup>2</sup>
General Waste	11,089	1100	11	7 per week	1.33	14.63
Cardboard & Paper Recycling	2,573	1100	4	3 per week	1.33	5.32
Confidential Paper Recycling	88	240	2	1 per week	0.43	0.85
Commingled Recycling	505	240	8	3 per week	0.43	3.41
Food Organics Recycling	20	500	5	7 per week	0.26	1.82
Clinical Waste	126	240	6	1 per month	0.43	2.56
Pharmaceutical Waste	8	120	1	1 per quarter	0.26	0.26
Sanitary Waste	589	28	10	1 per week	0.10	1.00
Circulation Space (+30% of bin footprint)	N/A					9.16
<b>Total</b>	<b>14,999</b>					<b>39.69</b>

HammondCare intends to reduce food wastage and its attendant environmental impacts through a variety of measures, including collection by a licensed contractor and/or on-site processing using an appropriate technology. The final choice of system will be reviewed and coordinated following lodgement of the EIS.

## 12 Operational Waste Management Processes

### 12.1 Clinical Wastes

Due to the risks involved with the generation and handling of these wastes, extreme care must be taken when handling, packaging, transporting and disposing of these materials. Consequently, there are strict requirements for all generators, transporters and disposal site operators to ensure protection to the community and the environment.

All clinical and related wastes must be:

- Handled by staff with access to appropriate Personal Protective Equipment (PPE)
- Packaged so that there is no risk of wastes escaping
- Transported and disposed of in accordance with EPA NSW legislation and guidelines and relevant Codes of Practice

The NSW Health *Clinical and Related Waste Management for Health Services Policy*, August 2017 provides clear guidance and detailed procedures for managing various types of clinical waste. These materials must be stored in uniquely identified receptacles located in separate rooms from all other wastes and recyclables, as per the colour-coding shown in Appendices 2 and 3 and disposed of according to designated Clinical and Hazardous Waste Procedures.

Clinical wastes may include:

- Anatomical
- Laboratory
- Sharps
- Cytotoxic
- Pharmaceutical
- Radioactive
- Chemical

**Anatomical, laboratory, and sharps wastes** must be managed using the following protocols:

1. Community sharps accepted or collected at a public hospital or authorised outlet of the Needle and Syringe Program are classified as clinical sharps waste and must be managed in accordance with this Policy.
2. Genetically modified organisms (GMOs) must be disposed of in clinical waste, except if the GMOs also contain cytotoxic waste, in which case they must be disposed of as cytotoxic waste for incineration.
3. Incontinence pads and disposable nappies can be treated as general waste unless the material is locally judged to come from an infectious patient (and consistent with the *CEC Infection Prevention and Control Practice Handbook*), is visibly blood stained, or is disposed of in a manner likely to cause offence such as in unusually large quantities, in which case it must be treated as clinical waste.
4. Sharps containers that are resistant to impact, penetration and leakage, are stable, have integrity of the handles/other carrying features and closure device, and have a capacity indicator (fill line) marked on the outside wall of the container must be used.
5. Reusable sharps containers must be readily emptied and cleaned before reuse.
6. Microbiological and pathological wastes must be decontaminated in accordance with *Australian and New Zealand Standard 2243.3: Safety in Laboratories* and shredded by the waste contractor prior to disposal.

7. Waste service providers require the application form for approval of a method to treat clinical waste if they collect, transport and treat clinical waste. Refer to the *Guideline for Approval of Method to Treat Clinical Waste*.
8. Reclassify waste in accordance with the EPA step-by-step waste classification process after treatment and before recycling or disposal.
9. For further clarification on requirements for disposal of infectious substances, refer to the most current *Australian and New Zealand Standard 2243.3: Safety in Laboratories*.

**Cytotoxic, pharmaceutical, and radioactive wastes** must be managed as follows:

1. Radioactive sharps must be placed in a clinical sharps bin and the bin must be labelled with a radioactive sticker while the waste is radioactive, the name of the substance, activity level and the date at which it is measured. When radioactivity decays to background, the sticker must be removed and waste disposed of as clinical waste.
2. For requirements on medication handling and recommended destruction of Schedule 8 Medications, refer to NSW Health Policy Directive *Medication Handling in NSW Public Health Facilities* (PD2013\_043).
3. Refer to the RPS No.20 *Safety Guide for Classification of Radioactive Waste* for the classification of radioactive waste in consideration of long-term safety and disposal of the waste.
4. Refer to the EPA classification guidelines for the step-by-step procedure to classify and manage radioactive waste.
5. For guidance on safe handling, segregation and storage of radioactive waste, refer to Part A2 'Requirements for Radioactive Waste' of the Code of Practice for Radiation Protection in the Medical Applications of Ionizing Radiation (RPS14). The Radiation Management Plan document needs to address dose limit requirements for the public and occupationally exposed persons as provided in Schedule 5 of the Radiation Control Act 1990.
6. The policy and procedure for radioactive sharps waste management is to be determined locally, e.g. storage in a dedicated room.
7. Specific obligations are placed on the responsible person (including obtaining consent) and transporter by the *Code for the Safe Transport of Radioactive Material* (RPS2) which is mandated by the *Radiation Control Regulation 2013*.

**Chemical wastes** must be managed as follows:

Chemical waste is to be classified in accordance with the step-by-step process in the *Waste Classification Guidelines Part 1: Classifying Waste* and the ADG Code. These wastes must be managed and disposed of as per the Safety Data Sheet (SDS) for the hazardous chemical and recommended handling precautions, PPE and disposal.

All containers containing chemical waste must have labelling as per the requirements in Part 3 of Schedule 9 Classification, packaging and labelling requirements of the *WHS Regulation 2017* and the *Labelling of Workplace Hazardous Chemicals Code of Practice*. This applies for a waste product that is reasonably likely to be a hazardous chemical. The waste is to be packed in a container with a label in English including the following for the hazardous chemical:

- Product identifier
- Name, and the Australian address and telephone number of the manufacturer or importer
- Hazard pictogram and hazard statement consistent with the classification of the chemical

A licence may be required for the disposal of high activity level radioactive substances classified as hazardous waste in accordance with the *Waste Classification Guidelines Part 3: Waste Containing Radioactive Material*.

## 12.2 General Waste

General waste is to be contained in clearly labelled white or opaque bags. General waste is any waste that:

- Is not covered in Section 12.1
- Has not been in contact with infectious agents, hazardous chemicals or radioactive substances
- Does not pose a sharps hazard

General waste will be further separated into recyclable or compostable streams as described in Sections 12.3-12.8.

## 12.3 Cardboard and Paper Recycling

Most cardboard packaging will originate from deliveries of supplies and stationery. Paper materials such as non-confidential office paper, newspapers, magazines, etc. will be generated from offices, reception areas, and waiting rooms, and managed as follows:

1. Hospital staff will dispose of paper into correct bin within bin hubs
2. Hospital staff will flatten cardboard boxes and leave in designated area for collection
3. Cleaners will collect materials and transfer to the bins within storage room
4. Recycling contractor will collect from here according to designated schedule

## 12.4 Secure Document Destruction

These materials will be placed in 240-litre bins located in each office area and collected on an as-required basis by a specialist contractor. To avoid contractors using lifts for transporting these materials during busy times, the following system is recommended:

1. Hospital staff will dispose of secure documents into designated bin(s)
2. Hospital will arrange for cleaning contractor to collect bins and take to storage room
3. Secure document contractor will collect from here according to designated schedule

## 12.5 Commingled Recycling

Commingled recycling consists of all (non-hazardous) mixed plastic bottles and containers, glass bottles, and steel and aluminium cans. This material will have the following separation and collection processes:

1. Hospital staff will dispose of materials into correct bin within bin hubs
2. Cleaners will collect materials and transfer to the designated bins in storage room
3. Recycling contractor will collect from here according to designated schedule

## 12.6 Food Waste Recycling

There are significant opportunities for recycling food organics from the Hospital using the following process:

1. Hospital staff will dispose of materials into small bins for collection by cleaners
2. Cleaners take separated materials to organics bins in main Hospital bin storage area (alternatively to an onsite food waste processing unit)
3. Recycling contractor will collect from here according to designated schedule (or if food waste processing equipment is installed onsite, the processed end material will be reused on the Hospital's grounds)

## 12.7 Polystyrene Recycling

Variable quantities of polystyrene packaging will be generated from deliveries of medical supplies. An 1100-litre bin located in the main Hospital storage area will be used for these materials and collections will be done as required by the Hospital's recycling contractor.

1. Hospital staff will leave polystyrene boxes in designated area for collection
2. Cleaners will collect materials and transfer to the designated bin within storage room
3. Recycling contractor will collect from here as required

## 12.8 Specialised Recycling (E-Waste, Printer Cartridges, Lamps, Batteries)

Variable quantities of e-waste (discarded electrical and electronic items) will be generated from office areas and general hospital operations. A 240-litre bin is recommended for storage of these materials in the main Hospital bin area.

Used printer cartridges will be generated from office areas. The usual recycling system consists of a cardboard box supplied by the service provider (e.g. Planet Ark) that is located next to print facilities. The system will be managed by Facilities Maintenance staff, who will organize transfer of the full boxes to the main storage room.

Maintenance staff and electrical contractors are generally required to remove all lamps and globes generated through their activities for correct disposal offsite. Alternatively, a dedicated recycling box can be left in the main storage room for this purpose. The full box would be collected by a specialist contractor on request by the Hospital.

Used batteries would be stored and collected separately, or combined with the e-waste materials, depending on contract arrangements.

Appendix 7 provides diagrams and descriptions of materials movement pathways and workflows.

# 13 Operational Waste Stream Management

## 13.1 Labelling and Tracking

All waste containers and bin liners are to be correctly colour coded and identified. The labelling, packing and transport of Division 6.2 Infectious Substances must comply with the ADG Code for dangerous goods. These requirements typically apply for waste classified as UN 2814 (Category A Infectious Substances) and UN 3291 (Category B Infectious Substances).

Portable and mobile bins must be marked, labelled and placarded as required by Chapters 5.2 and 5.3 of the ADG Code. The Hospital will need to liaise with the transporter to ensure they have a transport document describing what is being transported, and comply with the record keeping requirements specified in the EPA clinical waste tracking exemption for clinical waste, cytotoxic waste, sharps waste, pharmaceuticals and poisons, and radioactive waste.

## 13.2 Mobile Garbage Bins (MGBs) and Trolleys

MGBs are re-usable rigid-walled containers used to contain and move clinical and related wastes. Trolleys are used to move clinical wastes contained in plastic bags or non-mobile rigid-walled containers.

MGBs and trolleys must be dedicated solely for collecting and transporting waste to decrease spills, eliminate direct contact with waste and minimise manual handling. MGBs and trolleys must be washable, with a lid that is lockable. MGBs must be securely closed during movement but not necessarily locked, unless the MGB is a pharmaceutical waste bin.

MGBs and trolleys must never be overfilled and the load is to not be more than three quarters full (i.e., less than 55 kg). Waste collection rounds are to be performed as often as necessary to minimise housekeeping hazards.

The following procedures are recommended to be regularly completed by the hospital:

- Rinse with cold water then wash with warm water and a neutral detergent, or equivalent (e.g., chemical formulated for cold water use)
- Trolleys and MGBs are to be drained to sewer and left to dry
- Clean trolleys and bins are to be stored separately to soiled containers
- Appropriate personal protective equipment must be worn when cleaning MGBs

In addition, MGBs are to be readily inspected and cleaned after each use by the waste contractor. Defective containers must be repaired before use or taken out of service. Plastic bags/liners must have sufficient strength to safely contain waste and be suitable for the purpose if used for moist heat sterilization. Chemical waste containers must be suitable for the chemical contained within and labelled.

### 13.3 Handling of Bags/Bin Liners

It is best practice to minimise the handling of waste bags and to avoid decanting from one bin to another. When clinical waste bags must be handled, all bags are to be held away from the body by the closed top of the bag, and placed directly into a bin appropriate to the waste (see Table 1).

Gloves, apron and protective eyewear must be worn when closing the bags and placing them into the container. Gloves worn are to be appropriate for the type of waste being handled.

Waste bags must not be filled to more than two-thirds capacity and contents are to be secured within the bag when closing. Excess air is to be excluded without compaction, prior to closure at the point of generation. The bag is not to be secured with sharp protuberances, e.g. staples.

All clinical waste stream bags and receptacles stored pending collection are to be in a secure area with restricted access. Pathology specimens and associated materials must be double packaged. Anatomical waste must be packaged to minimise the risk of contents spilling or puncturing the bin liner before being placed into the anatomical waste bin. This includes triple bagging of body parts or amputated limbs that may have sharp bone edges and/or the use of wet bags. Sharps must never be placed in waste bags.

### 13.4 Spill Management

Spills will be managed according to standard procedures. The hospital will ensure that:

- Personnel involved in spill management are trained in emergency procedures and handling requirements, including use of spill kits. Spill kits are to be readily accessible throughout the health service and clearly labelled and mapped
- Health services have personal protective equipment and emergency spill kits that are appropriate to the waste streams handled, so staff can safely and effectively clean spills and dispose of the waste
- Spill kits are restocked with the necessary components immediately after use, returned to their locations and regularly inspected for malfunctioning or missing components
- Spill kits are to be disposed of with the relevant waste stream

## 13.5 Auditing

Auditing is important to establish benchmarks and whether waste is appropriately managed. This includes reviewing contractor information and developing an agreed auditing process, including frequency and selection of samples. Audits will include:

- Checking waste streams are appropriately used and managed
- Checking that bags and MGBs/trolleys are not overloaded, creating the potential for spills
- Reviews of WMP procedures
- Interviews with key staff
- Reviews of records

Auditing is to be conducted at least quarterly to ensure correct management of all waste streams.

## 14 Waste and Recycling Contractor Requirements

### 14.1 Transport and Disposal

Transport documents must describe the dangerous goods being transported, and appropriate emergency information for those goods. The ADG Code requirements commonly apply for the packing and transport of the following waste categories:

- UN 2814 (Category A Infectious Substances): Infectious substances affecting humans
- UN 3291 (Category B Infectious Substances): Infectious substances which do not meet the criteria for inclusion in Category A, which includes clinical wastes which are reasonably believed to have a low probability of containing infectious substances

The SafeWork NSW factsheet *Packing and Transporting Clinical Waste* assists health services with the handling and transport of UN3291 clinical waste in accordance with Packing Instruction P62A of the ADG Code.

### 14.2 Servicing, Access, and Reporting

Currently, all collections take place from the Hospital's existing loading dock, located in the external carpark, 24 hours per day, 7 days per week. Waste collection for the Greenwich Redevelopment will be restricted to the hours of 7am-7pm from the new loading dock in Basement Level 1, as detailed in Section 15.

Currently, the site's waste contractor performs 12-15 collections per week from the external loading dock. Following the site's development, this will increase to 24-30 collections per week with increased quantities of operational waste and recycling and the addition of new recycling streams such as food organics and polystyrene recycling.

Differently sized collection vehicles may be used for collection of some waste streams; if so, the waste contractor will be responsible for notifying the Hospital in advance of any vehicles entering the site, to ensure heights and turning circles comply with access and clearance requirements. The contractor will also be required to comply with the following requirements:

- Reliable and efficient servicing, and meeting all agreed schedules
- Suitably sized collection vehicles to be able to access the loading dock
- Having collection vehicles fitted with suitable weighing technology
- Working with the Hospital to achieve improved resource recovery
- Maintaining accurate and comprehensive tracking systems for all materials collected
- Providing detailed monthly reports on diversion and financial outcomes
- Maintaining current details of processing facilities used, and providing information on these if requested by the Hospital



## 15 Storage and Loading Areas

All general waste and recycling storage facilities will be situated in the proposed new Basement Level 1 loading dock, with separate areas for storage of general waste, recycling, and hazardous waste, a bin wash area, and space for bulky goods storage.

The loading dock will operate between the hours of 7am-7pm, which is less than the current existing waste collection hours; however, most vehicle movements will still occur during business hours. Facility staff will be on site to manage dock usage and activity and supervise loading of materials into collection vehicles.

In future should HammondCare seek to extend these hours to 24/7 a modification application would be required including a quantitative assessment by the acoustic consultant.

Movement of the Loading Dock to this enclosed internal location will mitigate noise impacts from waste collection vehicles, and limit disruptions to the site's neighbours, residents, staff and visitors, as well as providing a safer and more efficient system for waste handling and storage.

Storage rooms will be locked and accessible by authorised staff only and will conform with the relevant specifications of the Lane Cove Council *Development Control Plan Part Q - Waste Management & Minimisation* (listed in Appendix 8 of this report).

All bins and other equipment containers will be clearly differentiated through appropriate signage and colour coding to reflect the materials contained, with each stream located in a designated area with colour-coded signage to assist in easy identification by users.

## 16 Internal Bins

### 16.1 Administrative Areas

These areas will be equipped with 4-stream bin hubs for:

- Paper/Cardboard Recycling
- Commingled Recycling
- Food Organics Recycling
- General Waste

Bins will be situated in areas which service a group of workstations and offices, as opposed to having bins under every desk; this improves cleaner efficiencies by reducing the number of bins that require collection and reduces the number of bin liners required. Offices with these types of systems typically achieve higher recycling rates than those with bins at desks or workstations.

Figure 2 shows examples of bins commonly used in office applications. Colour-coded translucent bin liners are recommended to assist cleaning staff to distinguish different materials streams and identify contamination prior to final disposal in the bins in the central storage room.

**Figure 2: Four-Stream Bin Configuration**



## 16.2 Clinical Areas

Clinical areas will have receptacles for the following streams located in dirty utility rooms:

- Commingled Recycling
- General Waste
- Clinical Waste
- Sharps Waste

## 17 Staff & Contractor Education

An education program will be implemented for all Hospital and Seniors Living staff following occupation of the development, to ensure the highest possible standard of waste management and diversion resource recovery.

Tenancy leases will contain clauses outlining compliance with the development's systems, and a continuing tenant education program will be implemented on an ongoing basis throughout the development's operational phase for all tenancies. New tenants will receive detailed information on the waste management and recycling programs as part of their leasing documentation.

Specific waste management clauses will also be written into cleaning contract specifications, including requirements for cleaning staff to monitor contamination of recycling streams and condition of bins and compactor equipment, and provide HammondCare with feedback on the ongoing performance of the waste management and recycling programs.

Examples of suitable bins and signage are presented in Section 16 and Appendices 3 and 4.

## 18 Operational Resource Recovery Targets

Specific targets for diversion of operational waste from landfill to resource recovery outcomes will form part of the contract between the development and its waste and recycling contractor(s). Using similar developments as a guide, we suggest the following targets:

**Year 1: 50% diversion/resource recovery**

**Year 2: 55% diversion/resource recovery**

**Year 3: 60% diversion/resource recovery**

To monitor progress towards these targets, ongoing reporting systems will be implemented as detailed below in Section 19.

## 19 Ongoing Performance Reporting

Following implementation of the new systems, a monthly reporting system, based on the Better Buildings Partnership (BBP) *Operational Waste Guidelines*, will be instituted. This will ensure the accurate tracking of performance, continued improvement, and cost-effective waste removal.

Specific performance clauses and KPIs in waste and cleaning contracts will ensure that all parties actively participate in the resource recovery initiatives and meet regularly to resolve performance issues and identify new improvement opportunities for.

Contractors will be required to report actual volumes and tonnages by stream so that site management can monitor performance and feed this back to stakeholders.

These processes should be supported by an annual weight-based physical audit of all non-hazardous materials streams, to be conducted by a qualified independent third party.



## Appendix 1: Glossary



Abbreviation/Term	Definition
Anatomical Waste	Limbs, organs, placenta, pathological specimens, biopsy specimens and body tissue taken during laboratory testing, surgery or autopsy and/or resulting from investigation or treatment of a patient.
Chemical Waste	Chemical waste generated by the use of chemicals in medical, veterinary and laboratory procedures.
Clinical Waste	(a) Human tissue waste (b) Discarded sharps (c) Laboratory waste (d) Animal waste
Commingled Recycling	Refers to a mixed container recycling stream. Typically this would include glass containers, aluminium cans, milk cartons, tins, and plastic containers. This stream does not strictly include any paper or cardboard materials however small portions of these materials are acceptable. Drinking glasses, ceramic mugs or plates, coffee cups or plastic bin liners are considered contaminants.
Contamination	Any item not designated under the contract as a recyclable.
Cytotoxic Waste	Material, which is, or may be, contaminated with a cytotoxic drug during the preparation, transport or administration of cytotoxic therapy.
General Waste	Assorted waste materials put into the recycling stream, usually characterised by being contained in plastic "garbage" bags. There may or may not be recyclable materials in the bag.
Hazardous Waste	Component of the waste stream which poses a danger to humans, the environment, equipment and physical structures.
Landfill	Land used for the burial of waste
Material Recovery Facility (MRF)	Plant and equipment for sorting and pre-processing materials from the waste stream for resource recovery.
MGB	Mobile Garbage Bin
Organic Waste	Component of the waste stream derived from living organisms.
Plastics:	
PET	Polyethylene Terephthalate. Clear, tough material that may come in different colours: used in soft drink bottles, as filling for pillows and sleeping bags and other textile fibres.
HDPE	High Density Polyethylene. Very common plastic usually white or coloured, used for milk and cream bottles, shampoo and cleaners, freezer bags and milk crates.
LDPE	A plastic material – Low Density Polyethylene, a soft flexible plastic that is made into the lids of icecream containers, garbage bags, garbage bins and black plastic sheet material.
PVC, UPVC, PPVC	Plastic materials in the polyvinyl chloride class. 1. UPVC is Unplasticised Polyvinyl Chloride which is usually made into clear cordial and juice bottles, blister packs and plumbing pipes and fittings. 2. PPVC is Plasticised Polyvinyl Chloride and is usually made up into items such as garden hose, shoe soles and blood bags and tubing.
PP	Polypropylene, a hard but flexible plastic that has many uses. Examples of uses are ice cream containers, potato crisp bags, drinking straws and hinged lunch boxes.
PS & EPS	Polystyrene 1. PS is a rigid brittle plastic that may appear clear and glassy. It is used for yoghurt containers, plastic cutlery and imitation "crystal" glassware. 2. EPS – expanded polystyrene is the white material that is made into hot drink cups, food containers, meat trays and fruit boxes.

Abbreviation/Term	Definition
Other Plastic	There is another category of plastic – Category 7 which includes all other plastics including acrylic and nylon.
Pharmaceutical Waste	Consists of pharmaceutical (drug, remedy/medicinal substance) or other chemical substance specified in the Poisons. Pharmaceutical waste, excluding cytotoxics, may arise from expired or discarded pharmaceuticals, those no longer required by patients, and waste materials/substances generated during the manufacture and administration of pharmaceuticals.
Recycled Materials	Materials recovered and manufactured into new products of the same general type (which may be manufactured from virgin recycled materials).
Recycling	Set of processes (including biological) for converting recovered materials that would otherwise be disposed of as wastes, into useful materials and or products.
Resource Recovery	Process that extracts material or energy for a useful purpose
Sharps Waste	Means any waste resulting from medical, nursing, dental, veterinary, pharmaceutical, skin penetration or other related clinical activity, and that contains instruments or devices: (a) That have sharp points or edges capable of cutting, piercing or penetrating the skin (e.g. needles, syringes with needles or surgical instruments), and (b)that are designed for such a purpose, and (c) that have the potential to cause injury or infection.
Waste	Materials and energy which have no further use and are released to the environment as a means of disposal.
Waste Generator	Any person or organisation that consumes goods and services resulting in addition to the waste stream.
Waste Management	Entire process of monitoring process of monitoring, collecting, sorting, storing and transporting for processing and reclamation of materials and energy resources and disposal of waste.

## Appendix 2: Clinical Waste Stream Management

The following tables are taken from the NSW Health *Clinical and Related Waste Management for Health Services* Policy and details procedures for management of waste and recycling streams that may be generated by the development's tenants during the operational phase.

Stream	Anatomical Waste	Clinical Sharps Waste	Clinical Waste (Including Pathological Waste)
Definition	Identifiable human body parts such as limbs, organs, placenta and recognisable or large pathological specimens resulting from investigation or treatment of a patient  It does not include deceased bodies	Any clinical object capable of inflicting a penetrating injury which may or may not be contaminated with blood and or body substance. This includes needles, ampoules and any other sharp objects or instruments designed to perform penetrating procedures  May contain clinical material or Genetically Modified Organism (GMO) waste	Clinical waste with the potential to cause injury, infection or offence: <ul style="list-style-type: none"> <li>Unrecognisable human tissue (excluding hair, teeth, nails and anatomical waste)</li> <li>Bulk blood or other body fluids (or body substances)</li> <li>Material and equipment visibly stained by blood or body fluids (includes incontinence pads and disposable nappies from an infectious patient)</li> <li>Lab specimens, cultures or other waste from lab investigations</li> <li>Waste from medical or veterinary research</li> <li>Genetically Modified Organisms (GMOs)</li> </ul>
Bin Colour	Yellow	Yellow	Yellow
Bin Lid Colour	Orange	Yellow	Yellow
Bin Liner	Orange	N/A	Yellow
Symbol			
Label (if GMOs present)		Contains GMOs	Contains GMOs
Specific Requirements	For incineration only	For incineration or autoclaving and shredding  Sharps containers must be rigid-walled and meet the requirements specified in AS/NZS 4031 and AS/NZS 4261[4,5]  Autoclave tape and bag indicators must be used to show autoclaving has been completed	For incineration or autoclaving [6] and shredding. Autoclave tape and bag indicators must be used to show autoclaving has been completed. Fluid may be able to be discharged into sewer depending on Liquid Trade Agreement between the health service and water utility  All clinical waste once treated by a process acceptable to NSW Health[7] may be reclassified in accordance with the Waste Classification Guidelines[8] before recycling or disposal  There are special precautions regarding disposal of waste related to cases of viral haemorrhagic fever

Stream	Anatomical Waste	Clinical Sharps Waste	Clinical Waste (Including Pathological Waste)
Relevant Act/ Regulation /Australian Standard	AS/NZS 3816:1998 Management of clinical and related waste AS/NZS 4123:2008 Mobile Waste Containers	AS/NZS 3816:1998 Management of clinical and related waste AS/NZS 4123:2008 Mobile Waste Containers <i>Protection of the Environment Operations Act 1997</i> <i>Protection of the Environment Operations (Waste) Regulation 2014</i>	AS/NZS 3816:1998 Management of clinical and related waste AS/NZS 4123:2008 Mobile Waste Containers <i>Protection of the Environment Operations Act 1997</i> <i>Protection of the Environment Operations (Waste) Regulation 2014</i>
EPA licence requirements	No	No	No
Stream	Cytotoxic Waste	Pharmaceutical Waste	Radioactive Waste
Definition	Material contaminated with residues or preparations containing materials toxic or otherwise harmful to cells. This includes any residual cytotoxic drug or laboratory chemical and any discarded material or clinical waste associated with the preparation or administration or excretion of cytotoxic drugs May include Genetically Modified Organisms (GMOs) or tissues containing GMOs	Pharmaceuticals or other chemical substances specified as regulated goods in the Poisons and Therapeutic Goods Act 2008. Includes any substance specified in a Schedule of the Poisons List under the Act, as well as any therapeutic good which is unscheduled Includes expired or discarded pharmaceuticals, filters or other material contaminated by pharmaceutical products	Waste material, including sharps and clinical waste contaminated with a radioisotope which arises from the medical or research use of radionuclides, e.g. during nuclear medicine, radioimmunoassay and bacteriological procedures, and may be in solid, liquid or gaseous form, and which emits a level of radiation above the level set by regulatory authorities
Bin Colour	Purple	Red	Red
Bin Lid Colour	Purple	Red	Red
Bin Liner	Purple	N/A	Red
Labelling of Bins	Cytotoxic waste	Pharmaceutical waste	Radioactive waste plus specific requirements below
Symbol		None	
Label (if GMOs present)	Contains GMOs		

Stream	Cytotoxic Waste	Pharmaceutical Waste	Radioactive Waste
Specific Requirements	For incineration only Collection, transport and handling only by licensed and registered waste management companies	Storage, destruction and disposal methods must comply with PD2013_043 Medication Handling in NSW Public Health Facilities Pharmaceutical waste must be incinerated at a licensed controlled waste facility. Certain pharmaceuticals may only be destroyed by authorised persons under the <i>Poisons and Therapeutic Goods Act 1966</i> Pharmaceutical waste bins must be lockable	Radioactive material to be stored on-site in appropriate storage area until it decays to below the thresholds of a "radioactive substance" as defined under the Radiation Control Act and Regulation Waste is to be classified with reference to the Safety Guide for the Classification of Radioactive Waste[4] and in accordance with the EPA Waste Classification Guidelines[5] Radioactive waste must be labelled with the substance, activity level and the date at which it is measured Handling and storage to comply with a Radiation Management Plan in accordance with the Code of Practice for Radiation Protection in the Medical Applications of Ionizing Radiation (ARPANSA 2008) Radioactive sharps When radioactive waste is to be transported, health services must comply with the Code of Practice for the Safe Transport of Radioactive Material (ARPANSA 2014)
Relevant Act & Regulation	AS/NZS 4123:2008 Mobile Waste Containers <i>Protection of the Environment Operations Act 1997</i> <i>Protection of the Environment Operations (Waste) Regulation 2014</i>	<i>Poisons and Therapeutic Goods Act 1966</i> <i>Poisons and Therapeutic Goods Regulation 2008</i>	AS/NZS 4123:2008 Mobile Waste Containers <i>Radiation Control Act 1990</i> <i>Radiation Control Regulation 2013</i>
EPA Licence Requirements	No	No	Yes - Waste Classification Guidelines Part 3: Waste containing radioactive material (EPA, 2014)

## Appendix 3: Signage Examples - Hazardous Waste

The examples below are for illustration purposes only.





## Appendix 4: Signage Examples - Internal and Loading Dock

The examples below are for illustration purposes only.



A large orange recycling symbol is centered at the top. Below it is a collection of various household waste items including plastic bottles, glass bottles, cardboard boxes, paper, metal cans, and plastic containers.

### mixed recycling

- ✓ metal
- ✓ glass
- ✓ plastic containers
- ✓ cartons
- ✓ paper
- ✓ cardboard



A large green recycling symbol is centered at the top. Below it is a pile of organic waste including fruit scraps, vegetable peels, coffee grounds, and tea bags.

### organic recycling

- ✓ fruit & vegetable scraps
- ✓ food leftovers
- ✓ coffee grounds & tea bags



A small green recycling symbol is at the top. Below it is the same collection of household waste items as in the first sign.

## MIXED RECYCLING

METAL, GLASS, CARTONS AND PLASTIC CONTAINERS  
PLUS PAPER AND CARDBOARD



A trash can icon is at the top. Below it is the word "LANDFILL" in large, bold, black letters. Underneath are two black plastic bags of waste. Surrounding the bags are several items in dashed-line boxes with arrows pointing to the bags: a coffee cup, a piece of blue plastic, a piece of white styrofoam, and a piece of brown paper.

## LANDFILL

PLASTIC BAGS, COFFEE CUPS, CLING WRAP, STICKY TAPE,  
WRAPPERS, POLYSTYRENE, BROKEN CROCKERY



# MIXED RECYCLING



# ORGANIC RECYCLING



METALS



GLASS



PAPER



FRUIT



VEGETABLES



FOOD SCRAPS



PLASTIC CONTAINERS



CARDBOARD



CARTONS



TEA BAGS



COFFEE GROUNDS



BREAD



## Appendix 5: Site Demolition Plans

The following drawings show the existing structures on site to be demolished. Bin storage zones for demolition waste are highlighted.

### Stage 1.1

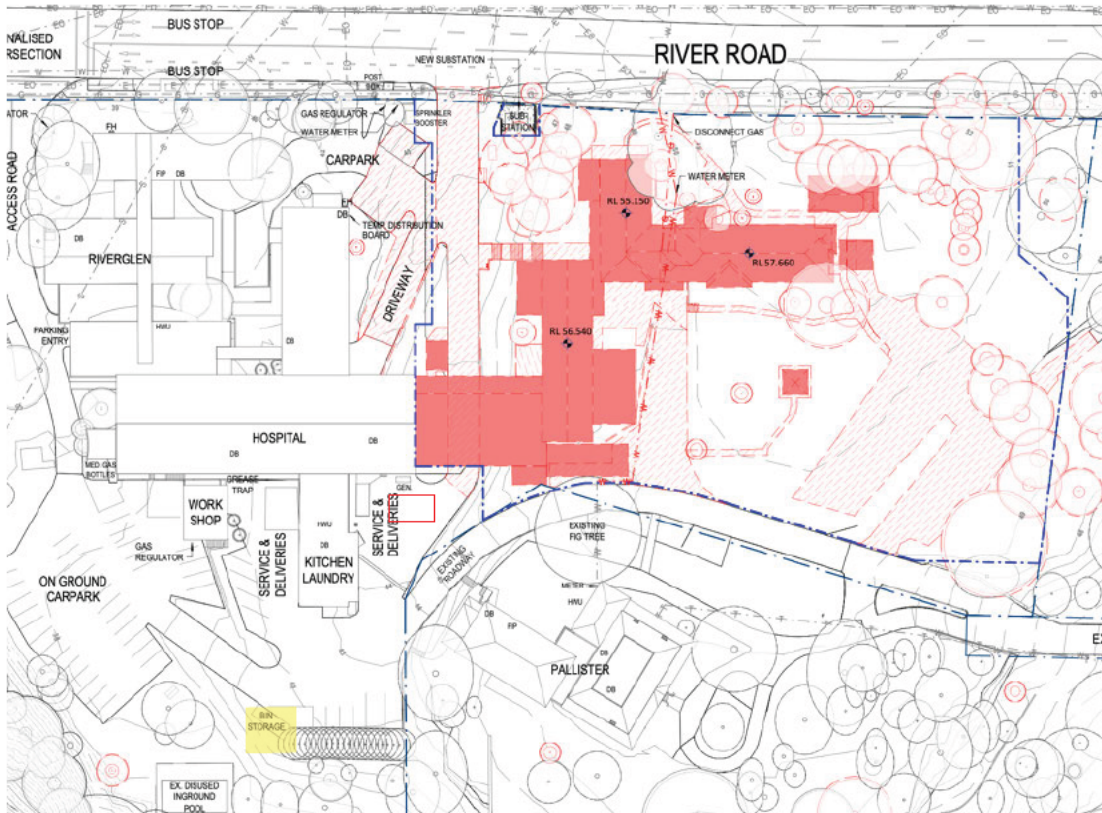

### Stage 3.1

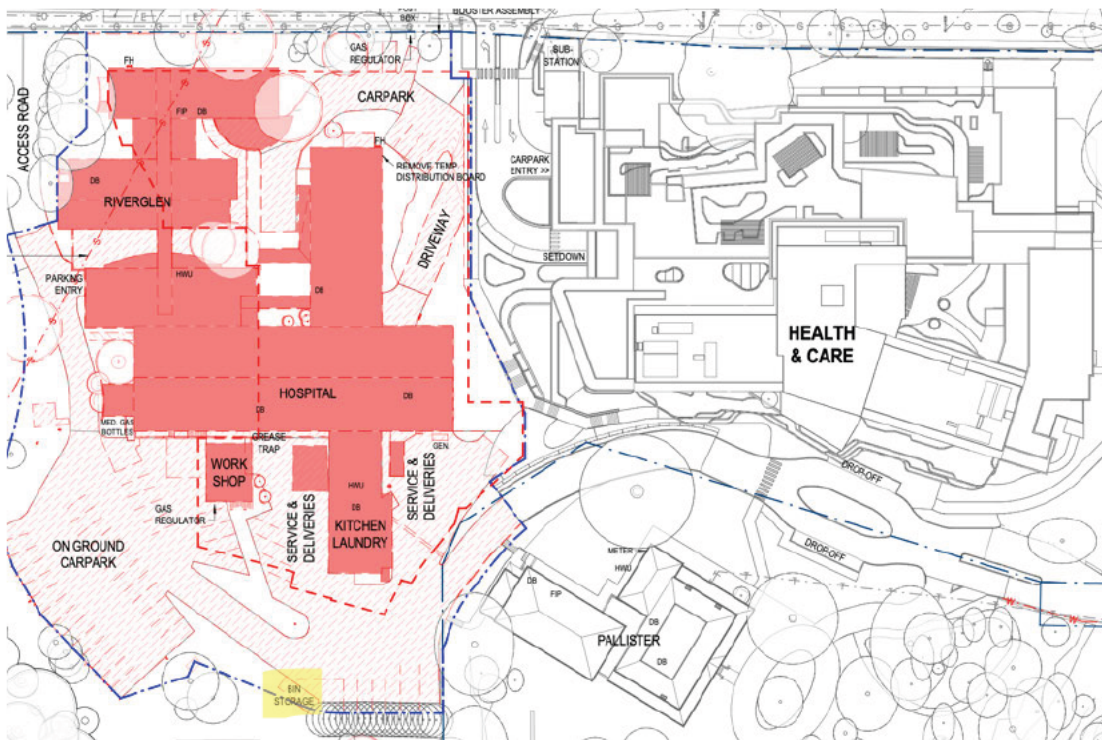

## Appendix 6: Site Construction Plans

The following drawings show the development's construction stages. Bin storage zones for construction waste are highlighted.

### Stage 1.2

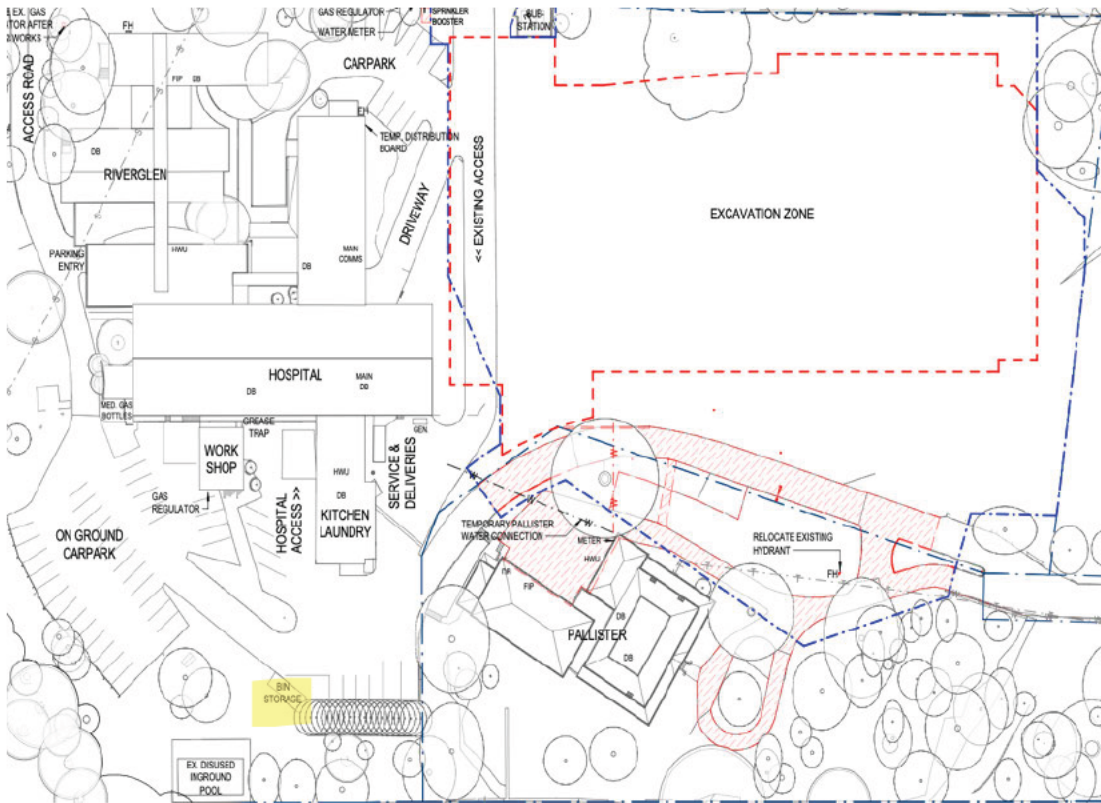

### Stage 2

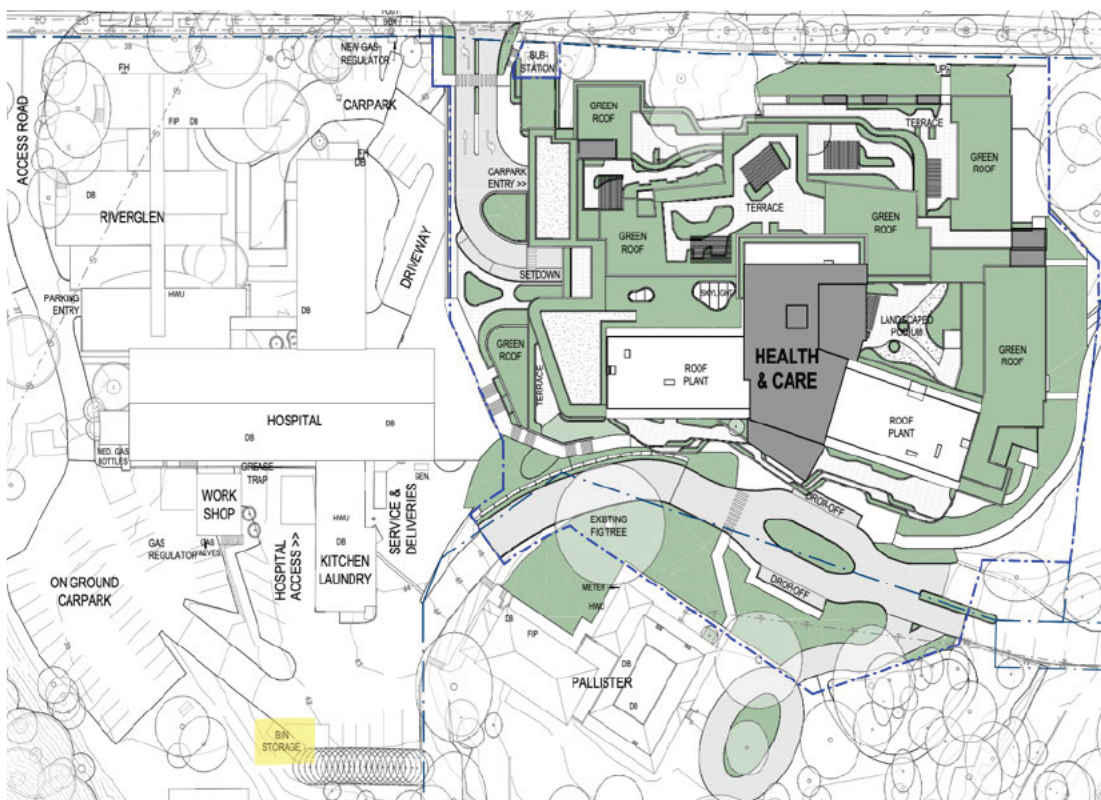

### Stage 3.2

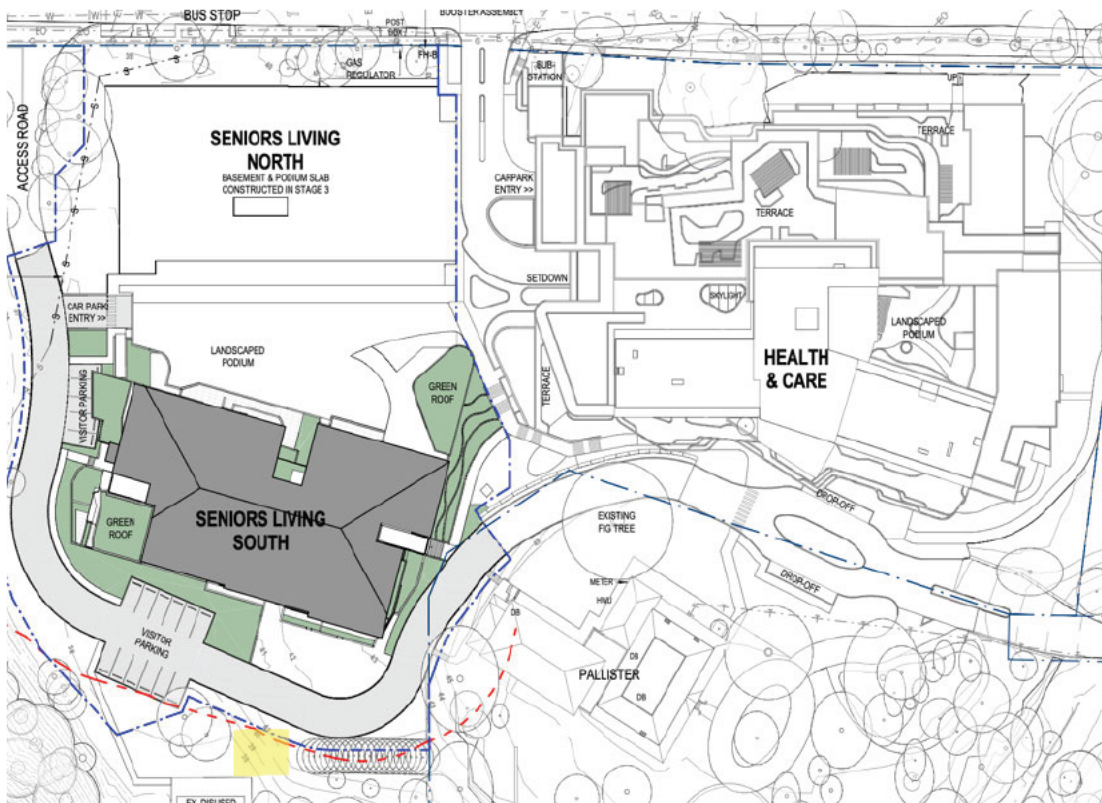

**Stage 4**

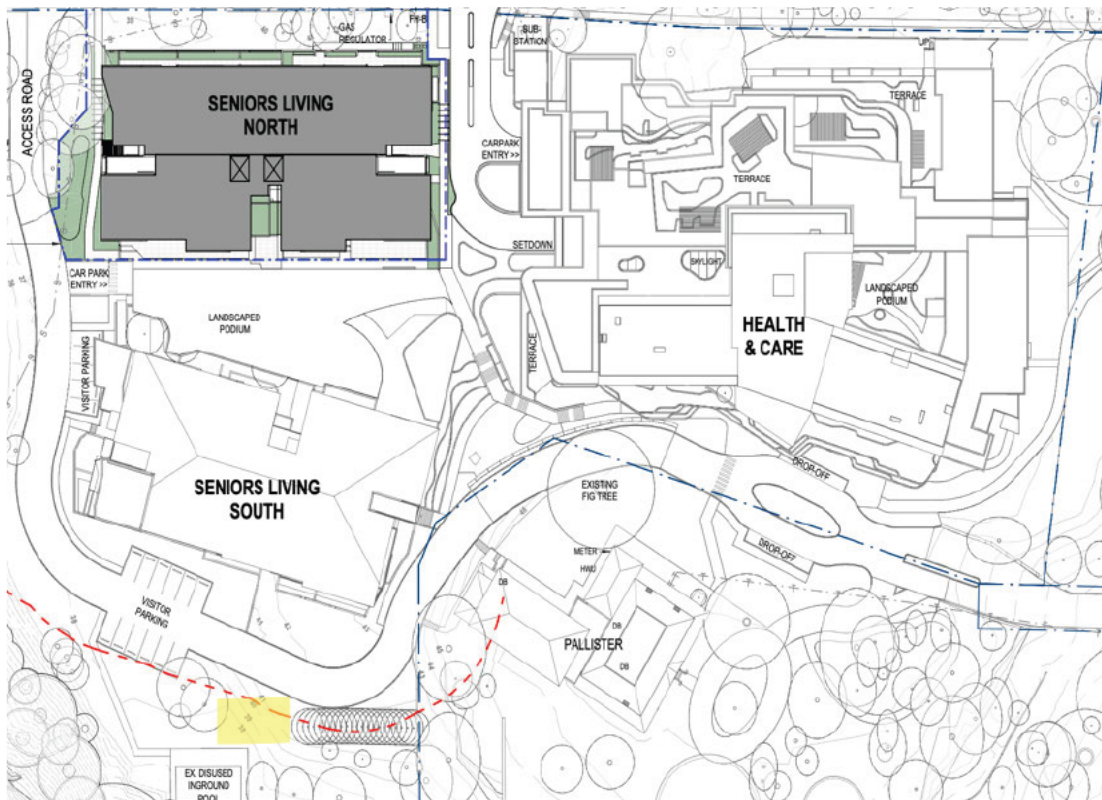

# Stage 5

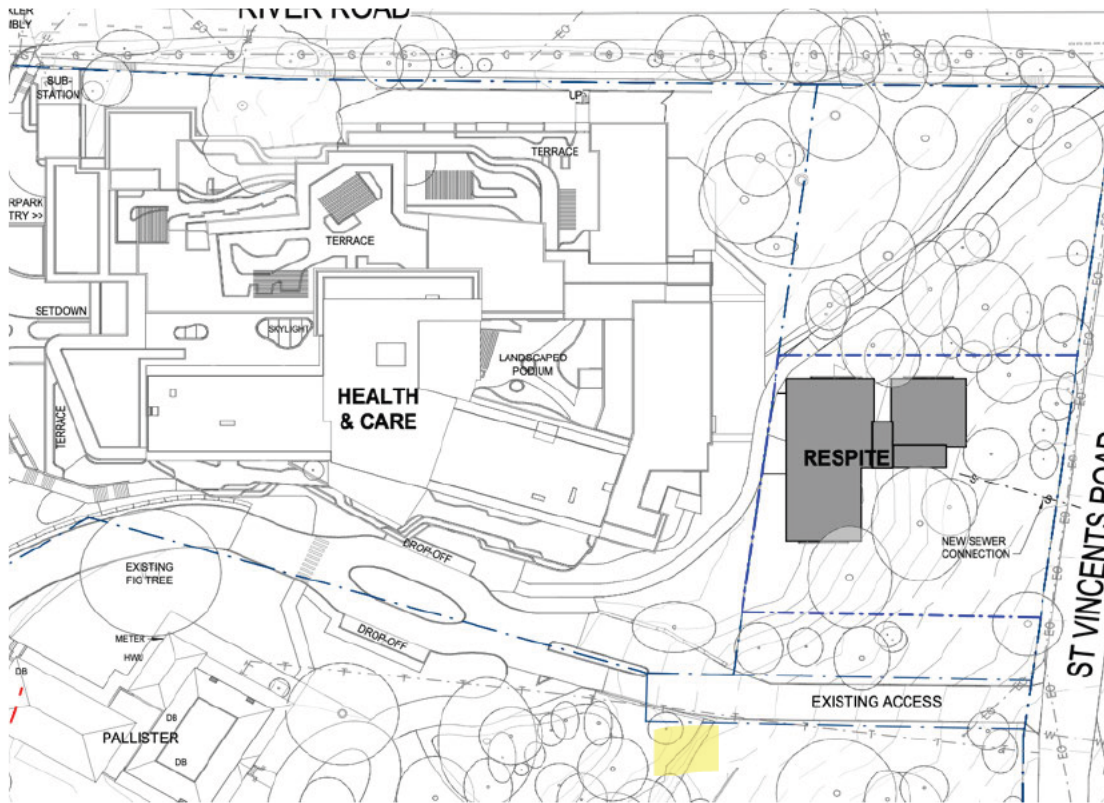

# Appendix 7: Materials Movement, Storage, and Collection

## Health & Care Level 1

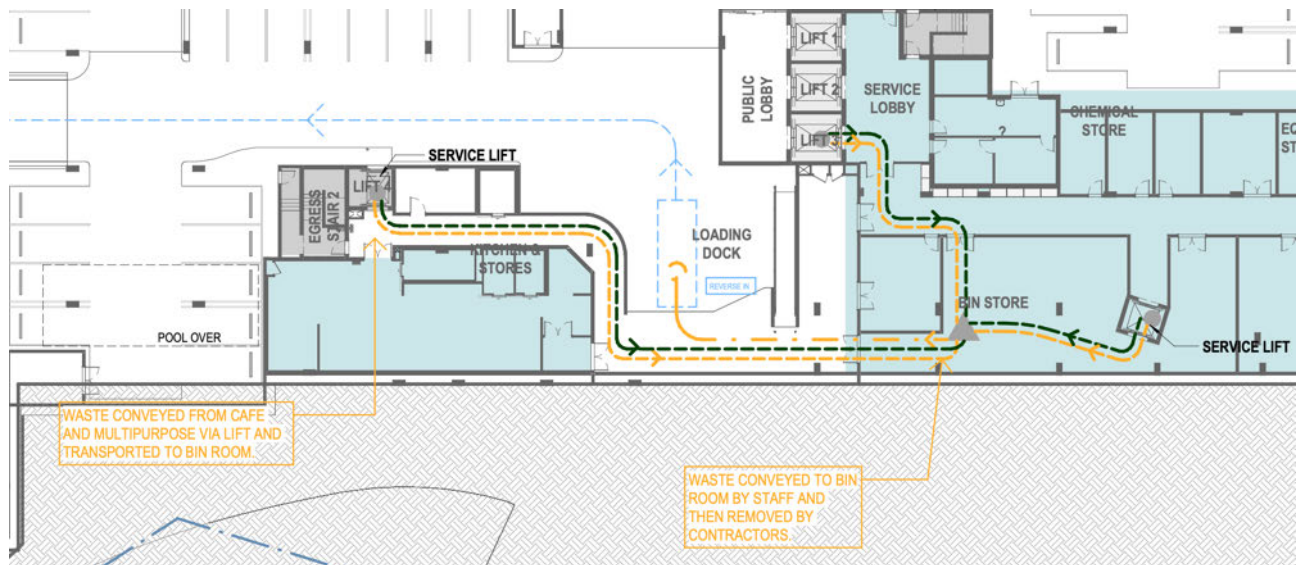

## Health & Care Level 2

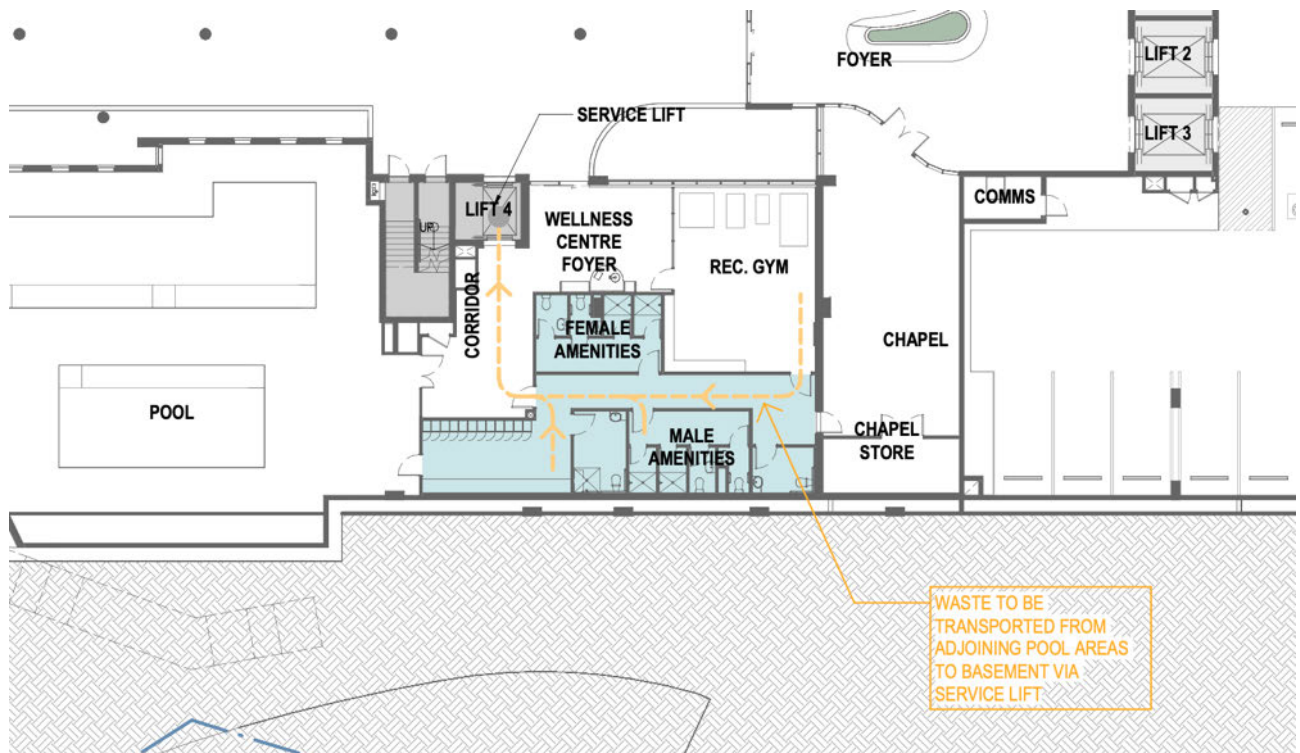

### Health & Care Level 3

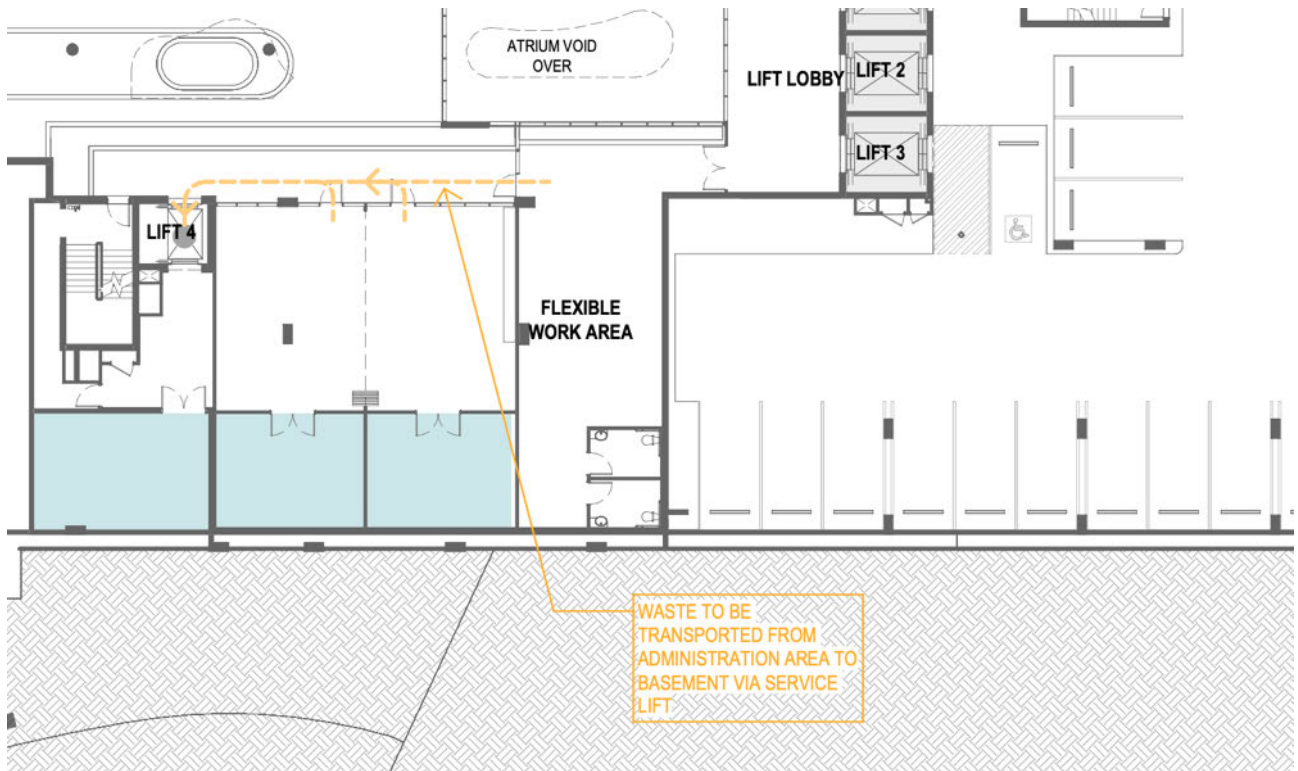

### Health & Care Level 4

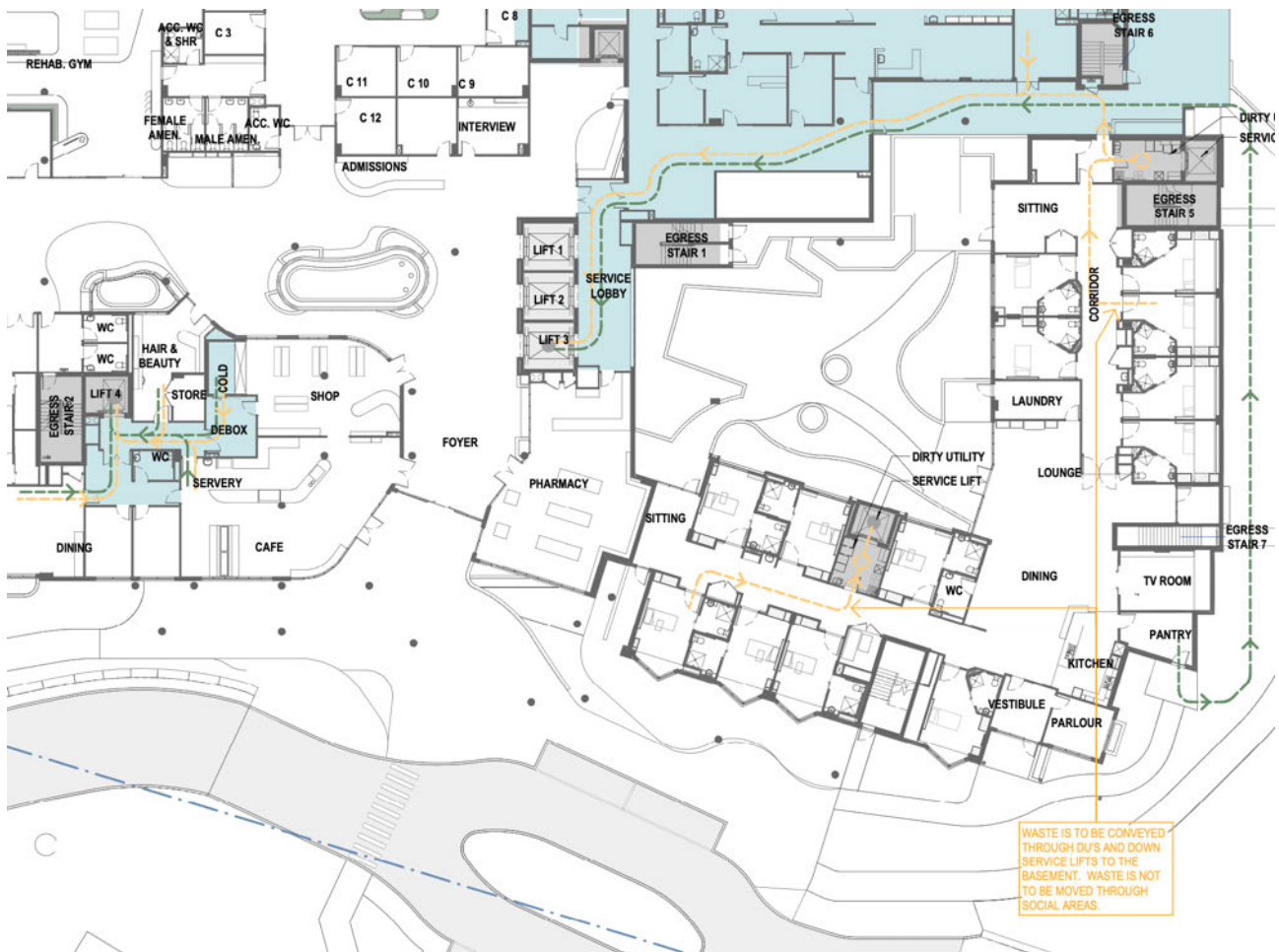



## Health & Care Level 5

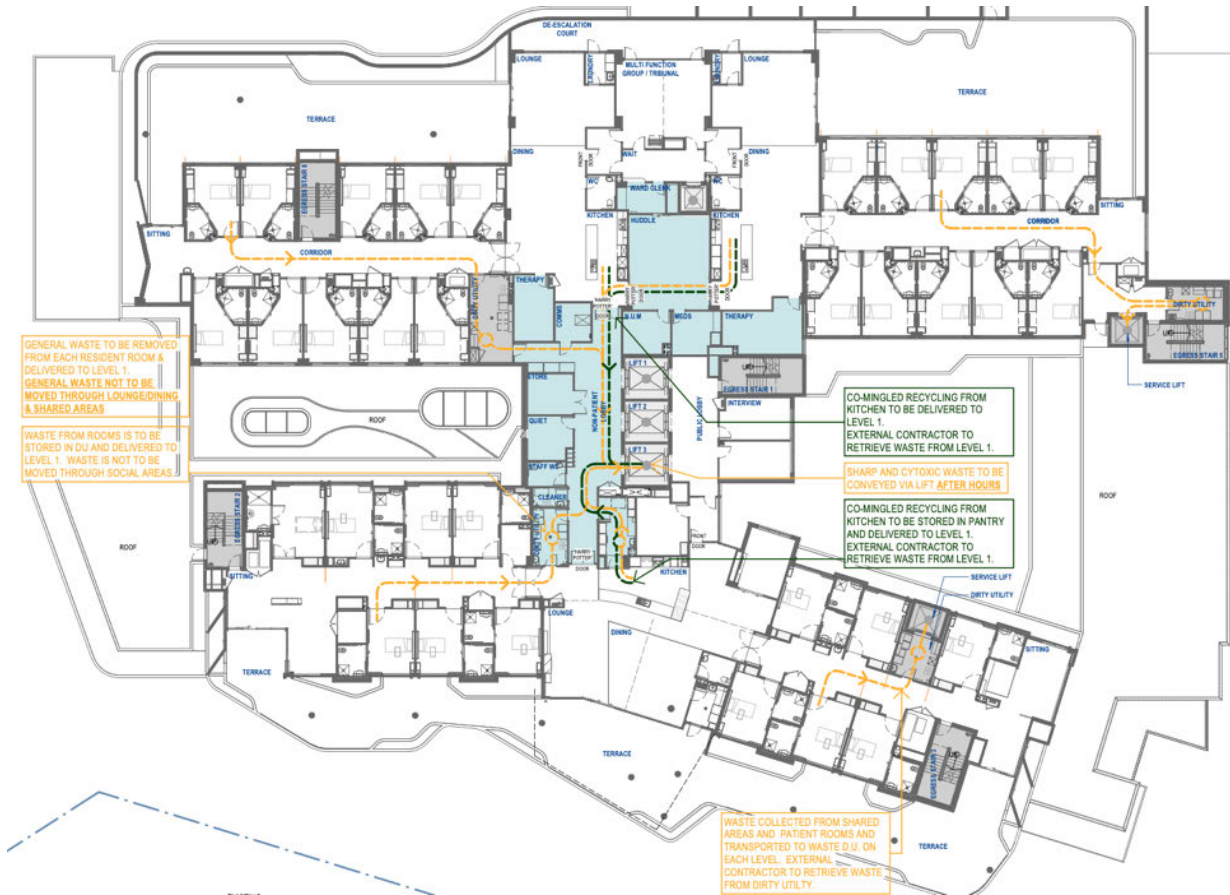

## Health & Care Level 6

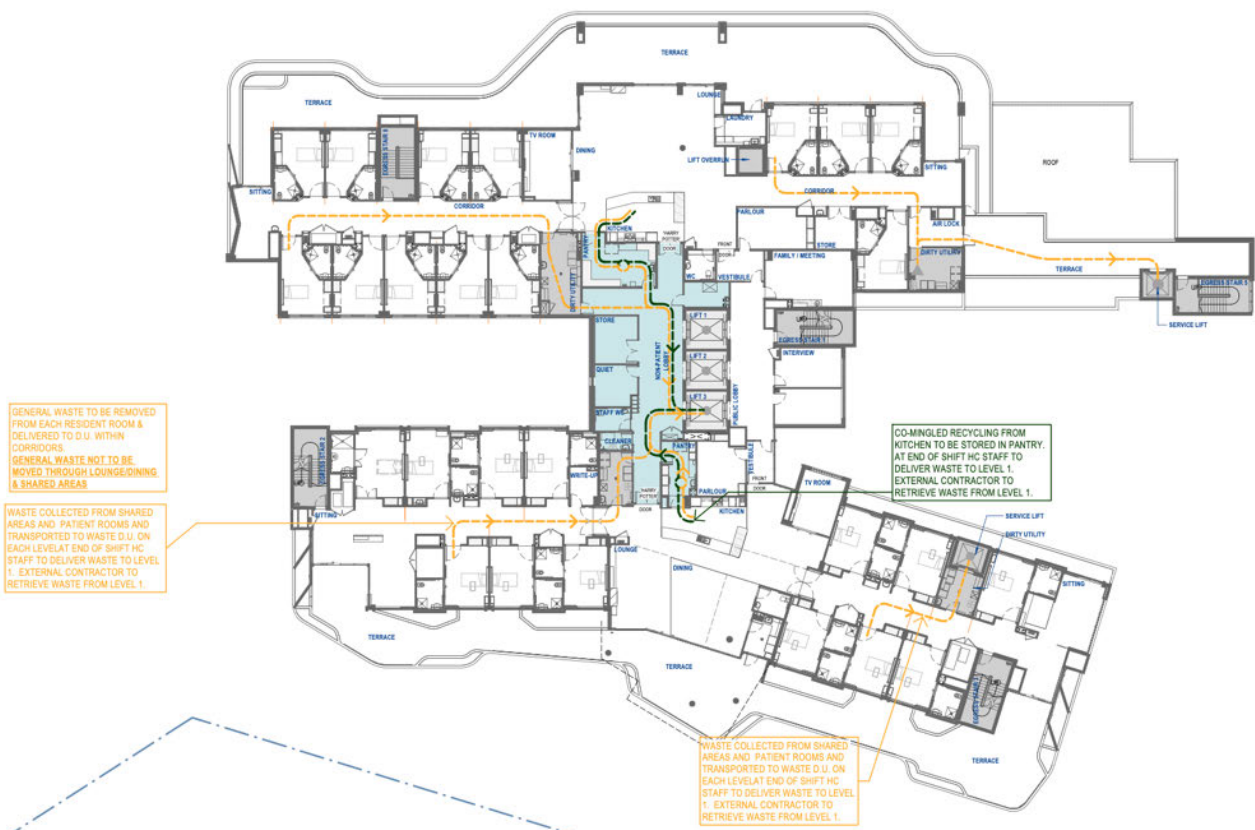

## Health & Care Level 7

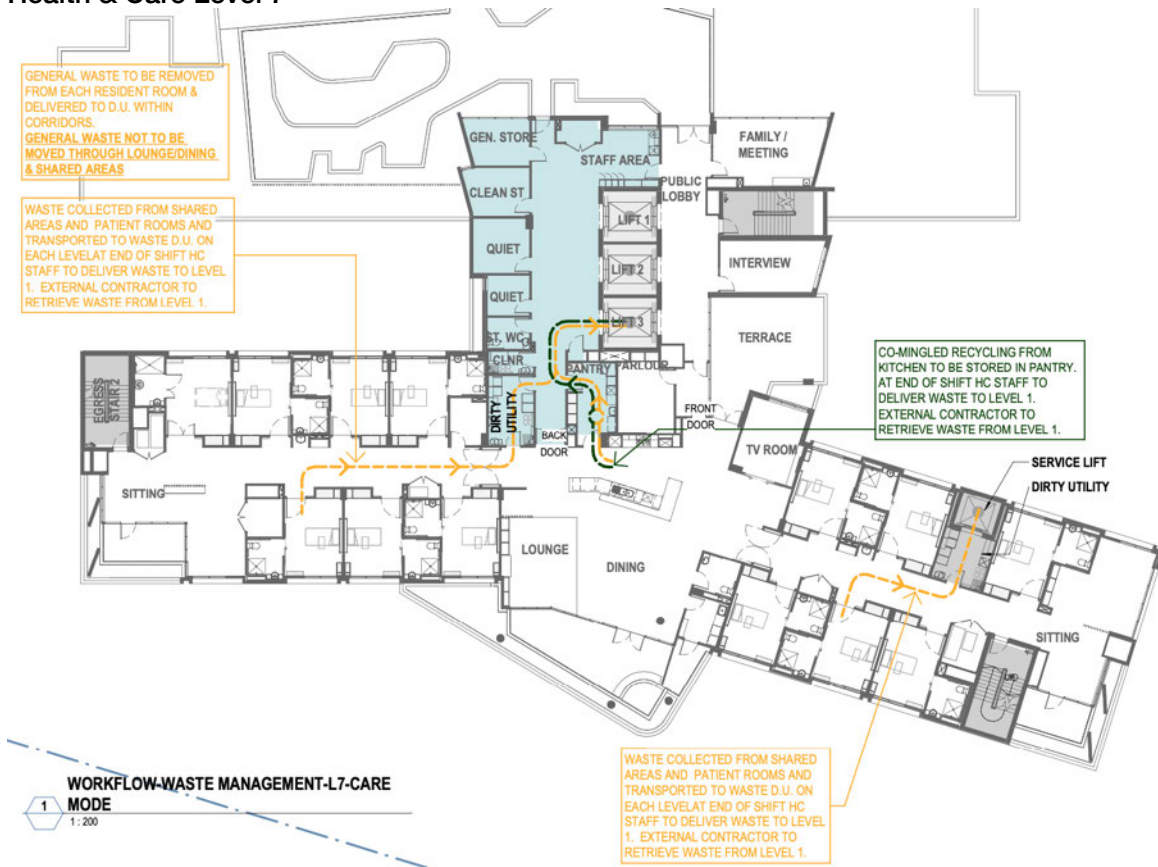

## Health & Care Typical Level

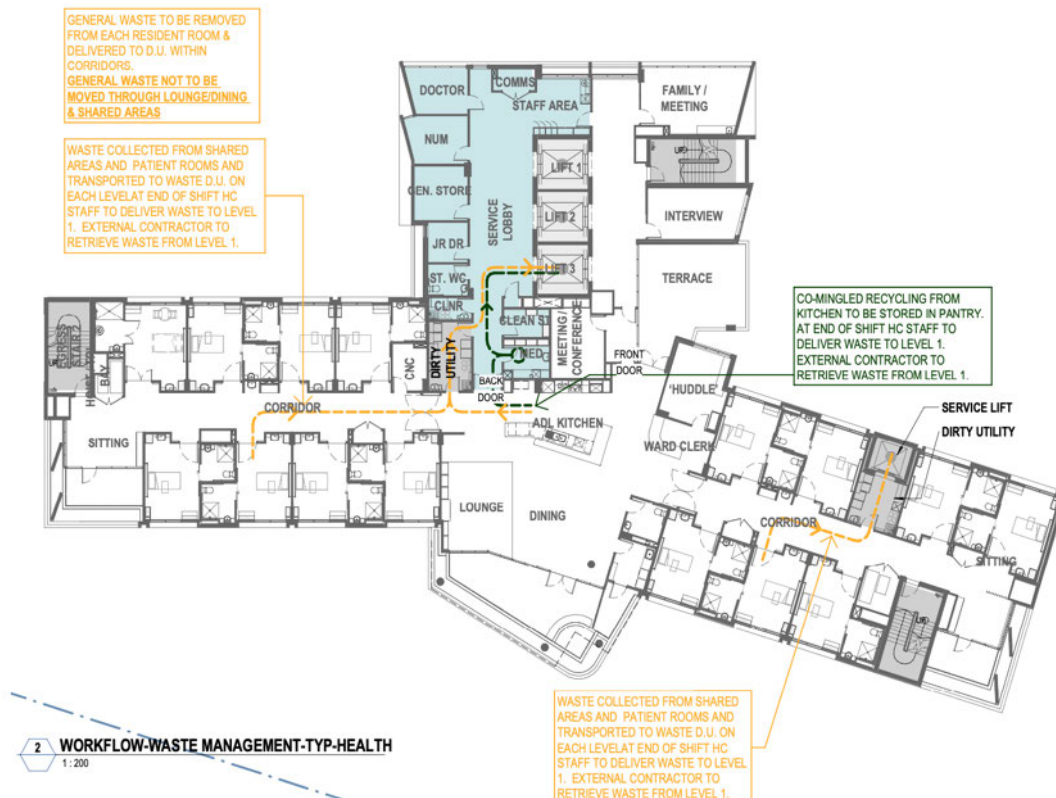

## Seniors Living Level 1

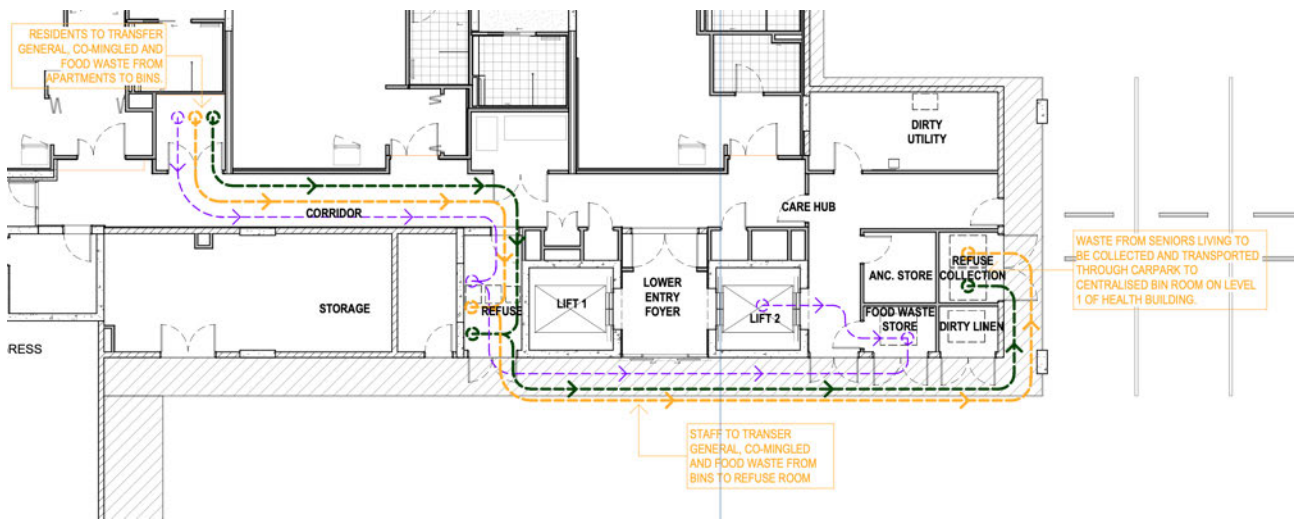

### Seniors Living Level 2

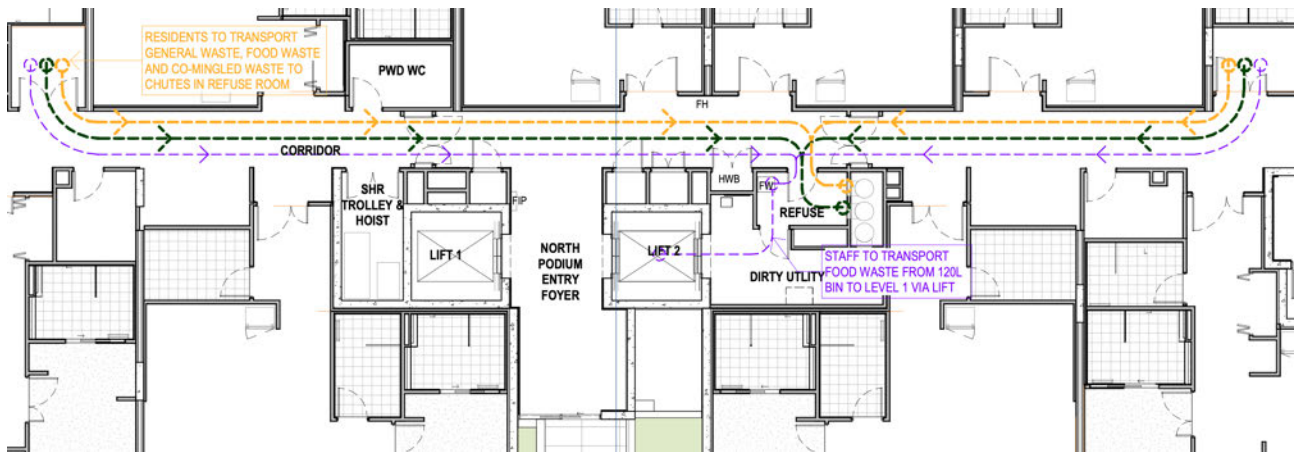

## Appendix 8: Lane Cove Council Waste Management Controls

The relevant sections of the Lane Cove Council *Development Control Plan Part Q - Waste Management & Minimisation* pertaining to the management of demolition, construction, and operational waste are reproduced below.

### 3.1 Demolition of Buildings or Structures

#### General

The demolition stage provides great scope for waste minimisation. Proponents are actively encouraged to consider possible adaptive reuse opportunities of existing buildings/structures, reuse of materials or parts thereof.

#### Aim

The principal aim of managing this activity is to maximise resource recovery and minimise residual waste from demolition activities.

#### Objectives

- 1 Optimise adaptive reuse opportunities of existing building/structures.
- 2 Maximise reuse and recycling of materials.
- 3 Minimise waste generation.
- 4 Ensure appropriate storage and collection of waste.
- 5 Minimise the environmental impacts associated with waste management.
- 6 Avoid illegal dumping.
- 7 Promote improved project management.

#### Controls/Requirements

- a) A completed Site Waste Minimisation and Management Plan (SWMMP) must accompany any demolition application.
- b) Pursue adaptive reuse opportunities of buildings/structures.
- c) Identify all waste likely to result from the demolition, and opportunities for reuse of materials. Refer to Figure 1.
- d) Facilitate reuse/recycling by using the process of 'deconstruction', where various materials are carefully dismantled and sorted.
- e) Reuse or recycle salvaged materials onsite where possible.
- f) Allocate an area for the storage of materials for use, recycling and disposal (giving consideration to slope, drainage, location of waterways, stormwater outlets, vegetation, and access and handling requirements).
- g) Provide separate collection bins or areas for the storage of residual waste.
- h) Clearly 'signpost' the purpose and content of the bins and storage areas.

- i) Implement measures to prevent damage by the elements, odour and health risks, and windborne litter.
- j) Minimise site disturbance, limiting unnecessary excavation.

When implementing the SWMMP the applicant must ensure:

- Footpaths, public reserves, street gutters are not used as places to store demolition waste or materials of any kind without Council approval.
- Any material moved offsite is transported in accordance with the requirements of the Protection of the Environment Operations Act (1997).
- Waste is only transported to a place that can lawfully be used as a waste facility.
- Generation, storage, treatment and disposal of hazardous waste and special waste (including asbestos) is conducted in accordance with relevant waste legislation administered by the EPA and relevant Occupational Health and Safety legislation administered by WorkCover NSW.
- Evidence such as weighbridge dockets and invoices for waste disposal or recycling services are retained.

Note: Materials that have an existing reuse or recycling market should not be disposed of in a landfill. Figure 1 provides a list of some potential reuse/recycling options. Reuse and recycling opportunities are decreased when asbestos is not carefully removed and segregated from other waste streams.

## 3.2 Construction of Buildings or Structures

### General

Attention to design, estimating of materials and waste sensitive construction techniques and management practices can achieve significant rewards in managing waste.

### Aim

The principal aim of managing this activity is to maximise resource recovery and minimise residual waste from demolition activities.

### Objectives

- 1 Maximise reuse and recycling of materials.
- 2 Minimise waste generation.
- 3 Ensure appropriate collection and storage of waste.
- 4 Minimise the environmental impacts associated with waste management.
- 5 Avoid illegal dumping.
- 6 Promote improved project management.
- 7 Optimise adaptive reuse opportunities of existing building/structures.

### Controls / Requirements

- a) A completed Site Waste Minimisation and Management Plan (SWMMP) shall accompany the application.
- b) Note: The type of construction determines whether a development application, construction certificate or complying development statement is required. In all cases a SWMMP must be completed. Maximum waste minimisation and management benefits are achieved when the SWMMP is considered from the earliest stages of the development.
- c) Estimate volumes of materials to be used and incorporate these volumes into a purchasing policy so that the correct quantities are purchased. For small-scale building projects see the rates in Appendix B Waste/Recycling Generation Rates for a guide.
- d) Identify potential reuse/recycling opportunities of excess construction materials.
- e) Incorporate the use of prefabricated components and recycled materials.
- f) Arrange for the delivery of materials so that materials are delivered 'as needed' to prevent the degradation of materials through weathering and moisture damage.
- g) Consider organising to return excess materials to the supplier or manufacturer.
- h) Allocate an area for the storage of materials for use, recycling and disposal (considering slope, drainage, location of waterways, stormwater outlets and vegetation).
- i) Arrange contractors for the transport, processing and disposal of waste and recycling. Ensure that all contractors are aware of the legal requirements for disposing of waste.
- j) Promote separate collection bins or areas for the storage of residual waste.

- k) Clearly 'signpost' the purpose and content of the bins and storage areas.
- l) Implement measures to prevent damage by the elements, odour and health risks, and windborne litter.
- m) Minimise site disturbance and limit unnecessary excavation.
- n) Ensure that all waste is transported to a place that can lawfully be used as a waste facility.
- o) Retain all records (i.e. weighbridge dockets or invoices) demonstrating lawful disposal of waste and keep them readily accessible for inspection by regulatory authorities such as council, DECC or WorkCover NSW.

## 4.4 Commercial Developments and Change of Use (Shops, Offices, Food Premises, Hotels, Motels, Licensed Clubs, Education Establishments, Entertainment Facilities and Hospitals)

### General

A range of non-residential uses present an array of unique waste minimisation opportunities and management requirements. Flexibility in size and layout is often required to cater for the different needs of multiple tenants as well as future changes in use.

Note: Storage and disposal of liquid waste, such as oils and chemicals, are not covered by Part Q - Waste Management & Minimisation.

### Aim

To ensure new developments and changes to existing developments are designed to maximise resource recovery (through waste avoidance, source separation and recycling); and to ensure appropriate well-designed storage and collection facilities are accessible to occupants and service providers.

### Objectives

- 1 Ensure appropriate waste storage and collection facilities.
- 2 Maximise source separation and recovery of recyclables.
- 3 Ensure waste management systems are as intuitive for occupants as possible and readily accessible to occupants and service providers.
- 4 Ensure appropriate resourcing of waste management systems, including servicing.
- 5 Minimise risk to health and safety associated with handling and disposal of waste and recycled material and ensure optimum hygiene.
- 6 Minimise adverse environmental impacts associated with waste management.
- 7 Discourage illegal dumping by providing on site storage and removal services.

### Controls/Requirements

A completed Site Waste Minimisation and Management Plan (SWMMP) shall accompany the application.

Note: The nature of the development or change in use will determine whether a development application or construction certificate is required. In all cases a SWMMP must be completed. Maximum waste minimisation and management benefits are achieved when the SWMMP is considered from the earliest stages of the development.

Plans submitted with the SWMMP must show:



- a) The location of the designated waste and recycling storage room(s) or areas, sized to meet the waste and recycling needs of all tenants.
- b) The location of temporary waste and recycling storage areas within each tenancy. These are to be of sufficient size to store a minimum of one day's worth of waste.
- c) An identified collection point for the collection and emptying of waste and recycling bins.
- d) The path of travel for moving bins from the storage area to the identified collection point (if collection is to occur away from the storage area).
- e) The on-site path of travel for collection vehicles (if collection is to occur on-site).

There must be convenient access from each tenancy to the waste/recycling storage room(s) or area(s). There must be step-free access between the point at which bins are collected/emptied and the waste/recycling storage room(s) or area(s).

Every development must include a designated waste/recycling storage area or room(s) (designed in accordance with Appendix G Commercial/Industrial Waste and Recycling Storage Areas).

Depending upon the size and type of the development, it may be necessary to include a separate waste/recycling storage room/area for each tenancy.

All commercial tenants must keep written evidence on site of a valid contract with a licensed waste contractor for the regular collection and disposal of the waste and recyclables that are generated on site.

Between collection periods, all waste/recyclable materials generated on site must be kept in enclosed bins with securely fitting lids so the contents are not able to leak or overflow. Bins must be stored in the designated waste/recycling storage room(s) or area(s).

Arrangements must be in all parts of the development for the separation of recyclable materials from general waste. Arrangements must be in all parts of the development for the movement of recyclable materials and general waste to the main waste/recycling storage room/area. For multiple storey buildings, this might involve the use of a goods lift.

The waste/recycling storage room/area must be able to accommodate bins that are of sufficient volume to contain the quantity of waste generated (at the rate described in Appendix B Waste/Recycling Generation Rates) between collections.

The waste/recycling storage room/area must provide separate containers for the separation of recyclable materials from general waste. Standard and consistent signage on how to use the waste management facilities should be clearly displayed.

The type and volume of containers used to hold waste and recyclable materials must be compatible with the collection practices of the nominated waste contractor.

Waste management facilities must be suitably enclosed, covered and maintained so as to prevent polluted wastewater runoff from entering the stormwater system.

Where possible, waste/recycling containers should be collected from a rear lane access point. Consideration should be given to the time of day at which containers are collected so as to minimise adverse impacts upon residential amenity, pedestrian movements and vehicle movements.

The size and layout of the waste/recycling storage room/area must be capable of accommodating reasonable future changes in use of the development.

A waste/recycling cupboard must be provided for each and every kitchen area in a development, including kitchen areas in hotel rooms, motel rooms and staff food preparation areas. Each waste/recycling cupboard must be of sufficient size to hold a minimum of a single day's waste and to hold separate containers for general waste and recyclable materials.

Premises that discharge trade wastewater must do so only in accordance with a written agreement from the local sewer authority. In the Sydney Metropolitan Area (SMA) this is Sydney Water. Sydney Water defines trade wastewater as "any liquid, and any substance contained in it, which may be produced at the premises in an industrial and commercial activity, but does not include domestic wastewater (e.g. from hand-basins, showers and toilets)."

Premises which generate at least 50 litres per day of meat, seafood or poultry waste must have that waste collected on a daily basis or must store that waste in a dedicated and refrigerated waste storage area until collection.

Arrangements must be in place regarding the regular maintenance and cleaning of waste management facilities. Tenants and cleaners must be aware of their obligations in regards to these matters.

Any garbage chutes must be designed in accordance with the requirements of Appendix F Garbage Chutes, the Building Code of Australia.. Garbage chutes are not suitable for recyclable materials and must be clearly labelled to discourage improper use.

# Appendix G: Commercial/Industrial Waste and Recycling Storage Areas

## 1.1 Building Code of Australia

- a) Waste/recycling storage areas must be constructed in accordance with the requirements of the Building Code of Australia (BCA).

## 1.2 Location and appearance

- a) Waste/recycling storage areas must be integrated into the design of the overall development. Materials and finishes that are visible from outside should be similar in style and quality to the external materials used in the rest of the development.
- b) Waste/recycling storage areas must be located and designed in a manner that reduces adverse impacts upon neighbouring properties and the streetscape. The location and design of the areas should minimise adverse impacts associated with:
  - I. the proximity of the area to dwellings
  - II. the visibility of the area
  - III. noise generated by any equipment located within the area
  - IV. noise generated by the movement of bins into and out of the area
  - V. noise generated by collection vehicles accessing the site; and
  - VI. odours emanating from the area.

## 1.3 Size

- a) Waste/recycling storage areas must be of adequate size to comfortably accommodate all waste and recycling bins associated with the development.
- b) Waste/recycling storage areas must be able to accommodate separate general waste bins and recycling bins which are of sufficient volume to contain the quantity of waste generated (at the rate described in Appendix B) between collections.

## 1.4 Layout

- a) The gradient of waste/recycling storage area floors and the gradient of any associated access ramps must be sufficiently level so that access for the purpose of emptying containers can occur in accordance with WorkCover NSW Occupational Health and Safety requirements.
- b) Within waste/recycling storage areas, containers used for the storage of recyclable materials should be kept separate from (but close to) general waste containers — so that the potential for contamination of recyclable materials is minimised.

## 1.5 Access: waste/recycling collection

- a) The development must be designed to allow access by collection vehicles used by the nominated waste contractor. Wherever possible, the site must be configured to allow collection vehicles to enter and exit the site in a forward direction and so collection vehicles do not impede general access to, from and within the site. Access driveways to be used by collection vehicles must be of sufficient strength to support such vehicles.
- b) Servicing arrangements for the emptying of bins must be compatible with the operation of any other loading/unloading facilities on-site.
- c) Access for the purpose of emptying waste/recycling storage containers must be able to occur in accordance with WorkCover NSW Occupational Health and Safety requirements.

## 1.6 Access: general

- a) In commercial development, public buildings and industrial development, there must be convenient access from each tenancy to the waste/recycling storage area(s). There must be step-free access between the point at which bins are collected/emptied and the waste/recycling storage area(s).
- b) Arrangements must be in place so that the waste/recycling storage area is not accessible to the general public.
- c) Vermin must be prevented from entering the waste/recycling storage area.

## 1.7 Surfaces

- a) Waste/recycling storage areas must have a smooth, durable floor and must be enclosed with durable walls/fences that extend to the height of any containers which are kept within.

## 1.8 Doors/gates

- a) Doors/gates to waste/recycling storage areas must be durable. There must be a sign adjacent to the door/gate that indicates that the door/gate is to remain closed when not in use. All doors/gates are to be openable from both inside and outside the storage area and must be wide enough to allow for the easy passage of waste/recycling containers.

## 1.9 Services

- a) Waste/recycling storage areas must be serviced by hot and cold water provided through a centralised mixing valve. The hose cock must be protected from the waste containers and must be located in a position that is easily accessible when the area is filled with waste containers.
- b) The floor must be graded so that any water is directed to a sewer authority approved drainage connection located upon the site. In the SMA this is Sydney Water.

## 1.10 Signage

- a) Waste/recycling storage areas must include signage that clearly describes the types of materials that can be deposited into recycling bins and general garbage bins.

## 1.11 Management

- a) Arrangements must be in place for the regular maintenance and cleaning of waste/recycling storage areas. Waste/recycling containers must only be washed in an area which drains to a sewer authority approved drainage connection. In the SMA this is Sydney Water.

## Appendix 9: Waste Management Bins and Equipment

The dimensions shown below are indicative only and will be dependent on the waste contractor selected to service the development in its operational stage.

### 120-litre MGB

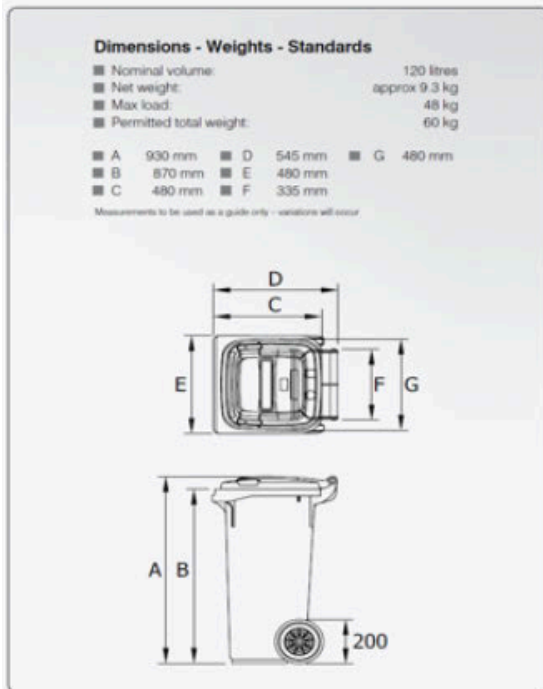

### 240-litre MGB

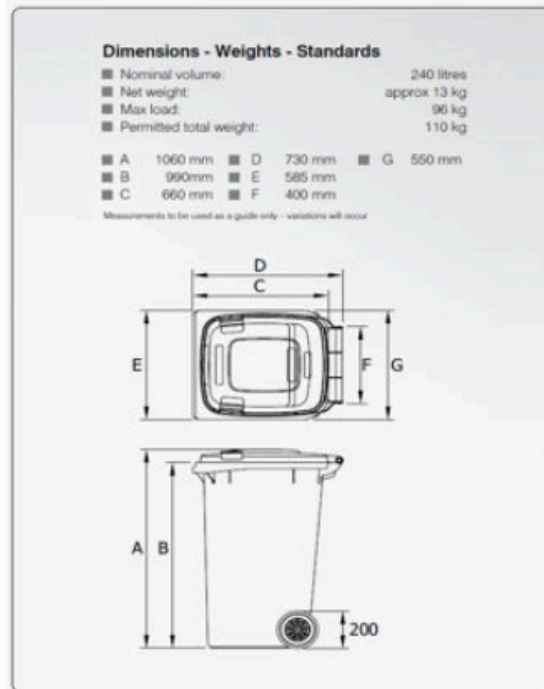

### 660-litre MGB



### 1100-litre MGB

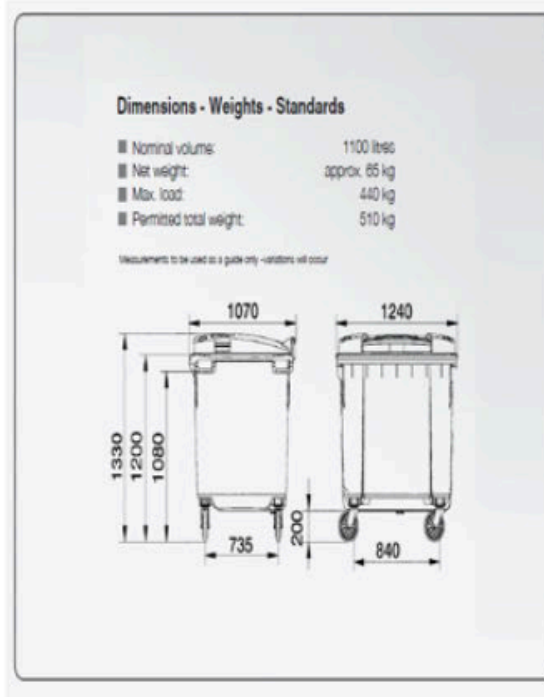

## Bin Movers and Tugs



## Waste Oil Recycling Equipment

